



1tRIPr XD
Operator's Manual

Part #125-024-01



Built for today's larger farms, the drawn *Orthman 1tRIPr[®] XD* offers the additional efficiency of fertilizer carrying capacity integrated in large-frame drawn designs. The *Orthman 1tRIPr[®] XD* is a great addition to the modern high horsepower farms.

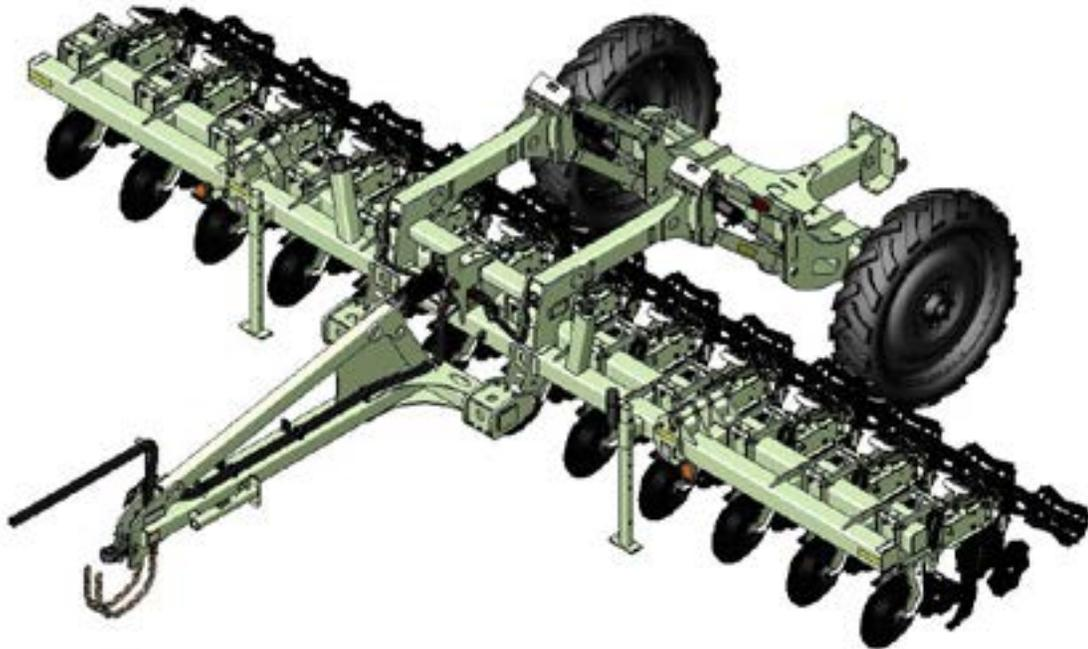

12 row 1tRIPr XD

The *Orthman 1tRIPr[®] XD* comes standard with Orthman *1tRIPr[®]* row units and can be equipped with either a 1,000 gallon liquid fertilizer package, a 6 or 9 ton dry fertilizer package, or the stand alone carrier (standard). For information regarding the specific fertilizer package on your machine, refer to the tooling options section of this manual. For information regarding the *1tRIPr[®]* row units, refer to the *1tRIPr[®]* operator's manual.

This manual is considered to be an integral component of the *1tRIPr[®] XD* and is designed to educate the owner and/or operator(s) regarding safety, operation, maintenance, troubleshooting, and component identification. All personnel involved in the operation of this implement are responsible for reading and understanding entire manual content. This manual is designed to keep the operator safe and knowledgeable as well as prolong the life of the implement and maximize field efficiency. This manual should accompany the implement if it were ever to be sold.

We would like to thank you for placing your confidence in Orthman Mfg., Inc. Your *1tRIPr[®] XD* is manufactured to meet the highest standards and is built with precision and strength to increase your agricultural operation's dependability and profitability.

Thank you for choosing Orthman.

To The Dealer:

Inspect the implement thoroughly after assembly to be certain it is functioning properly before delivering it to the customer. The following checklist is a reminder of points to cover. Check off each item as it is found satisfactory or after proper adjustment is made.

Pre-Delivery Checklist

- 1. All Hardware properly tightened.
- 2. Lubrication of grease fittings.
- 3. All decals properly located and readable.
- 4. All implement tools and options are installed and set.
- 5. Check overall condition of implement.
- 6. Make sure Operator's manual is included.

Date Set Up. _____

Signature. _____

Delivery

Review the operator's manual with the customer. Explain the following:

1. Introduce the machine to the customer. Give the customer this manual and encourage them to read it.
2. Make the customer aware of all the safety precautions that must be exercised when using and transporting this machine.
3. Make customer aware of the different tooling options available.
4. This machine does not come set to run in the field from the factory. The Field settings section in this manual is meant to help set the machine for optimal performance. Explain all operating adjustments.
5. Explain to the customer that the life expectancy of this machine depends on regular maintenance as directed in this manual.
6. Tell the customer to use the proper tools for service and make them aware of Orthman parts availability.
7. Write machine model number and serial number in the spaces provided below.

Date delivered. _____

Signature. _____

Model Number. _____

Serial Number. _____

WARRANTY

Orthman warrants each new wholegood product to be free from defects in manufactured components and workmanship. This warranty is applicable only for the normal service life expectancy of the product or components, not to exceed twenty-four (24) consecutive months from date of purchase of the new Orthman product to the original purchaser.

Purchased components installed by Orthman (blades, bearings, controls, hoses, wheels, coulters, cylinders, fittings, etc.) shall be warranted by the respective manufacturer for a period of twelve (12) consecutive months from date of delivery of the new Orthman product to the original purchaser.

A completed online Warranty Registration for the original purchaser must be received by Orthman to activate warranty coverage. Non-receipt of warranty registration may void warranty coverage. The Orthman warranty is non-transferable.

Genuine Orthman replacement parts and components will be warranted for ninety (90) days from date of purchase, or the remainder of the original equipment warranty period, whichever is greater.

All warranty work is to be performed by an authorized Orthman dealer at the repairing dealer's location, unless otherwise approved by Orthman.

Under no circumstances, will this warranty cover any merchandise or component thereof, which, in the opinion of Orthman, has been subjected to misuse, unauthorized modifications or alteration, accident, collision with obstruction/ground, or if repairs have been made with parts other than those obtainable through Orthman.

Orthman warranty policies do not cover travel expenses, after-hours field/service time, overnight expenses, or expenses not related to regular shop labor rates or parts replaced during actual warranty repair. Orthman reserves the right to adjust warranty labor credits to believed normal repair times as directed by state law(s).

This warranty shall be limited to repairing or replacing, free of charge to the purchaser, any part, which Orthman's judgment shows evidence of such defect. Additionally, the defective part(s) shall be returned within thirty (30) days from the date of failure to Orthman through the dealer or distributor from whom the product was purchased or repaired; transportation charges prepaid.

This warranty shall not be interpreted to render Orthman liable for injury or damages of any kind or nature to person or property. This warranty does not extend to the loss of crops, loss of delay in harvesting/planting, or any expense or loss incurred for labor, substitute machinery, rental, or any subsequent reasons thereof.

Except as set forth above, Orthman shall have no obligation or liability of any kind on account of its equipment and shall not be liable for special or consequential damages. **Orthman makes no other warranty, expressed or implied, and, specifically disclaims any implied warranty or merchantability or fitness for a particular purpose.** Some states or provinces do not permit limitations or exclusions of implied warranties or incidental or consequential damages, so the limitations or exclusion in this warranty may not apply. This warranty is subject to any existing conditions of supply, which may directly affect ability to obtain materials or manufacture replacement parts.

Orthman reserves the right to make improvements in design or changes in specifications at any time, without incurring any obligation to owners of units previously sold; to include, but not limit to engineering prototype machines. No one is authorized to alter, modify, or enlarge this warranty nor the exclusions, limitations, and reservations.

© Copyright 2014
Orthman Manufacturing Inc.
Lexington, Nebraska
All rights reserved.

Orthman provides this manual without warranty of any kind, expressed or implied. This manual reflects the product at the time of publication. All information within is based upon current information on the publication date. Orthman assumes no responsibility for damages incurred due to the use of the illustrations, information, and specifications within this publication.

TABLE OF CONTENTS

INTRODUCTION

General Information - 1tRIPr® XD 1 - 1
 Warranty Information 1 - 2
 Delivery Checklist 1 - 3
 Table of Contents 1 - 4

IMPORTANT SAFETY INFORMATION

Farm Safety..... 2 - 1
 Your Protection - Equipment Safety - Safety Alert Symbol 2 - 3
 Signal Words - Shutdown and Storage 2 - 4
 Safe Transport - Warning and Safety Lights 2 - 5
 Safe Operation - No Riders..... 2 - 6
 Practice Safe Maintenance..... 2 - 7
 Practice Safe Maintenance - Prepare for Emergencies 2 - 8
 Anhydrous Ammonia - Liquid Fertilizer Precautions - Safety Never Hurts 2 - 9
 Safety Decals 2 - 10
 Orthman Decals and Orthman Serial Tag..... 2 - 14

PREPARATION AND SETUP

Toolbar Component Identification..... 3 - 1
 Narrow Transport Toolbar Component Identification 3 - 2
 Tongue Component Identification 3 - 3
 Carrier Component Identification 3 - 4
 Light Kit Component Identification 3 - 5
 Shipping Configuration..... 3 - 6
 Preparing the Machine - Machine to Tractor Connection 3 - 7

TOOLING OPTIONS

Tongue Tab 4 - 1
 Fertilizer Packages (Liquid Fertilizer) 4 - 2
 Fertilizer Packages (Dry Fertilizer) 4 - 3
 Additional Options (Scale Kit, Nurse Tank Hitch) 4 - 4

SMART IMPLEMENT GUIDANCE

Component Identification..... 5 - 1
 Preparation and Set-Up - Preparation for Use 5 - 2
 Calibration 5 - 3
 Hydraulics 5 - 6

FIELD SETTINGS

Field Operation..... 6 - 1
 Bar Stand Placement 6 - 1
 Rigid Operation - Wing Leveling 6 - 2
 Narrow Transport Toolbar Stands..... 6 - 3
 Toolbar Height and Orientation..... 6 - 4
 NT Toolbar Folding Process..... 6 - 5

TABLE OF CONTENTS

HYDRAULICS

Standard Manifold Block Identification.....7 - 1
 NT Manifold Block Identification.....7 - 2
 Standard Machine Fold Hydraulic Hose Routing7 - 3
 Machine Lift Hydraulic Hose Routing7 - 4
 NT Machine Fold Hydraulic Hose Routing.....7 - 5

TROUBLESHOOTING

Toolbar will not fold or unfold.....8 - 1
 Removal of internal cylinder assembly8 - 3
 Machine will not raise or lower8 - 5

MAINTENANCE

Practice Safe Maintenance9 - 1
 Torque Specifications.....9 - 2
 Lubrication9 - 3
 Implement Inspection9 - 6
 Implement Storage.....9 - 7

PARTS IDENTIFICATION

Tongue Assembly10 - 1
 Toolbar Hinge Assembly.....10 - 3
 Toolbar Center Section Assembly10 - 4
 Narrow Transport Toolbar Center Section Assembly10 - 5
 Carrier Assembly10 - 7
 NT Outer Wing Hinge Assembly10 - 9
 Small Wheel and Axle Package10 - 11
 Large Wheel and Axle Package10 - 12
 Camoplast TTS 30-1601 Track Package.....10 - 13
 Camoplast TTS 45-1811 Track Package10 - 14
 Standard Internal Fold Assembly10 - 15
 NT Mid-Wing Internal Fold Assembly.....10 - 16
 NT Outer Wing Fold Linkage Assembly.....10 - 17
 Hydraulic Cylinder (Wing Fold).....10 - 19
 Hydraulic Cylinder (Machine Lift)10 - 20
 Standard Hydraulic Manifold Assembly10 - 21
 NT Hydraulic Manifold/Gear Flow Divider Assembly10 - 22
 Hydraulic Hose Identification - Standard Wing Fold10 - 23
 Hydraulic Hose Identification - Narrow Transport Wing Fold.....10 - 25
 Hydraulic Hose Identification - Machine Lift10 - 27
 Smart Implement Guidance Steering Components10 - 29
 Smart Implement Guidance Steering Components10 - 30
 Steerable Wheel and Axle Assembly (Small Wheel).....10 - 31
 Steerable Wheel and Axle Assembly (Large Wheel)10 - 32
 Light Bracket Assembly10 - 33
 Light Kit Assembly10 - 34
 Liquid Fertilizer Package Assembly10 - 35
 Dry Fertilizer Package Assembly10 - 36

Farm Safety

Contrary to the popular image of fresh air and peaceful surroundings, a farm is not a hazard-free work setting. Every year, thousands of farm workers are injured and hundreds more die in farming accidents. According to the National Safety Council, agriculture is the most hazardous industry in the nation.

How You Can Improve Farm Safety

You can start by increasing your awareness of farming hazards and making a conscious effort to prepare for emergency situations including fires, vehicle accidents, electrical shocks from equipment and wires, and chemical exposures. Be especially alert to hazards that may affect children and the elderly. Minimize hazards by carefully selecting the products you buy to ensure that you provide good tools and equipment. Always use seat belts when operating tractors, and establish and maintain good housekeeping practices. Here are some other steps you can take to reduce illnesses and injuries on the farm:

- Read and follow instructions in equipment operator’s manuals and on product labels.
- Inspect equipment routinely for problems that may cause accidents.
- Discuss safety hazards and emergency procedures with your workers.
- Install approved rollover protective structures, protective enclosures, or protective frames on tractors.
- Make sure that guards on farm equipment are replaced after maintenance.
- Review and follow instructions in material safety data sheets (MSDSs) and on labels that come with chemical products and communicate information on these hazards to your workers.

Health and Safety Hazards on Farms

Farm workers including farm families and migrant workers are exposed to hazards such as the following:

Danger	Potential Effect or Injury	Prevention
Chemicals/Pesticides	Skin and respiratory injury or death	MSDS and proper Personal Protective Equipment. Review Manufacturers data sheets
Cold	Illness, Frostbite or death	Dress properly for the day.
Dust	Respiratory injury or explosive combinations	Be aware of your surroundings and activity
Electricity	Shock, burns, fire, death	Use a qualified professional for wiring dangerous electrical devices. Never overload a circuit. Replace damaged electrical devices or cords. Electrical tape will not insulate you from injury.
Grain bins, Silos	Entrapment, Suffocation, Explosion from formation of dangerous gases and poisoning.	Make sure the bin is properly ventilated and maintained. Never walk the grain.
Hand tools	Injury including cuts abrasions, electrocution, strains, sprains and death	Make sure you hand tools are in good condition. Never leave a damaged tooling accessible for someone else to use.
Highway traffic	Collisions resulting in injury or death	Follow regulations, stay alert. Avoid alcohol and use of communication devices while driving
Lifting & lifting devices	Back injury, sprains, strains. Falling material resulting in being struck or crushed by heavy material	Use proper lifting technique. Get help when the load is too heavy. Inspect chains, straps or cables routinely to make sure they are in good condition.
Livestock handling	Serious injury or death resulting from being pinned struck or trampled.	Always make sure you have adequate room and an escape route
Machinery/Equipment	Cuts, abrasions, amputations, death.	Thoroughly read and understand your Owners Equipment Manual. Never operate the equipment without guards in place. Make sure the equipment can not be energized or otherwise put into operation while you are working on it.
Manure pits	Explosion from formation of dangerous gases. Suffocation. Poisoning	Proper maintenance.
Mud	Sprains, strains, entrapment and suffocation. Eye injury and skin irritation.	Proper Personal Protective Equipment. In some conditions a "Spotter" may be needed.
Noise	Hearing damage	Personal Protective Equipment.
Ponds	Drowning	Wear a life preserver and make sure help is readily available.
Slips/Trips/Falls	Sprains, strains, back and neck injury, bone breaks or death	Keep work area free from clutter and organized. If working on anything elevated make sure you have appropriate guarding and/or fall protection such as a harness and lanyard.
Sun/Heat	Sun burn, Heat Stroke, shock, death	Use common sense on excessively hot days, use sun screen, wear a hat and stay hydrated.
Toxic gases	Skin and respiratory injury or death. Explosion.	MSDS and proper Personal Protective Equipment. Review Manufacturers data sheets
Tractors	Cuts, abrasions, amputations, death.	Thoroughly read and understand your Owners Equipment Manual. Never operate the equipment without guards in place. Anti-roll over devices.
Wells	Electrocution, amputation, death	Avoid contact with water while working on an electrical device. Always be sure the equipment can/will not be energized during repair or maintenance. Make sure all guarding is in place.
Severe Weather	Electrocution, "struck by" injuries, death	Move to a safe place. Lightning, hail and tornadoes are unpredictable.

Orthman Manufacturing, Inc. does not limit the potential effects or injuries nor prevention measures to those listed above. They are provided solely as a guideline to making your farm life safer. Always consult your Owner/Operators Manual for specific tool and equipment safety requirements.

SAFETY INFORMATION

High Risk Factors on Farms

The following factors may increase risk of injury or illness for farm workers:

- Age – Injury rates are highest among children age 15 and under and adults over 65.
- Equipment and Machinery – Most farm accidents and fatalities involve machinery. Proper machine guarding and doing equipment maintenance according to manufacturers' recommendations can help prevent accidents.
- Protective Equipment – Using protective equipment, such as seat belts on tractors, and personal protective equipment (such as safety gloves, coveralls, boots, hats, aprons, goggles, face shields) could significantly reduce farming injuries.
- Take precautions to prevent entrapment and suffocation caused by unstable surfaces of grain storage bins, silos, or hoppers. Never "walk the grain."
- Be aware that methane gas, carbon dioxide, ammonia, and hydrogen sulfide can form in unventilated grain silos and manure pits and can suffocate or poison workers or explode.
- Take advantage of safety equipment, such as bypass starter covers, power take-off master shields, and slow-moving vehicle emblems.
- Medical Care – Hospitals and emergency medical care are typically not readily accessible in rural areas near farms.

The Benefits of Improved Safety and Health Practices

Orthman Manufacturing Provides this document in the hope that everyone that has a job to do, does it SAFELY. Our goal and yours should be to end each day in the best possible health. Better safety and health practices reduce fatalities, injuries, and illnesses as well as associated costs such as workers' compensation insurance premiums, lost production, and medical expenses. A safer and more healthful workplace improves morale and productivity.

SAFETY INFORMATION



⚠ FOR YOUR PROTECTION

READ AND UNDERSTAND THE ENTIRE CONTENT OF THIS MANUAL BEFORE OPERATING OR SERVICING IMPLEMENT. Read and understand all operator manuals for the machinery used in conjunction with your Orthman equipment.

- Carefully **READ ALL SAFETY DECALS** in this manual as well as on the implement. Keep implement clean so decals are easily visible. Keep all safety decals in good, clean, and legible condition. Immediately replace damaged and/or missing decals. Replacement decals are available from your Orthman dealer.
- Learn to operate the implement and all components properly. Do not let others operate implement without proper instruction. Unauthorized implement modifications may impair function and safety. If you do not understand any content in this manual or need assistance, contact your Orthman dealer.

⚠ EQUIPMENT SAFETY GUIDELINES

Operator safety is the primary concern when designing an Orthman implement. Orthman integrates as many safety features into the implement as possible. You can avoid many hazards and possible accidents by observing precautions in this safety section.

- Insist that yourself and personnel working with and around you follow all safety precautions. Be cautious when working with or around implement to avoid injury.

SAFETY ALERT SYMBOL

The **SAFETY ALERT SYMBOL** warns of potential hazards to personal safety and that extra precautions must be taken. When you see this symbol, carefully read the message(s) that follow. Follow all recommended precautions and safe operating practices in this manual.

NOTE: Hazard control and accident prevention are dependent upon the safety awareness and proper training of personnel involved in the operation of this implement.



⚠ BE AWARE OF SIGNAL WORDS

SIGNAL WORDS designate a degree or level of **HAZARD** seriousness. These signal words include:



DANGER indicates a hazardous situation that, if not avoided, will result in death or serious injury. **DANGER** is limited to extreme situations, typically for machine components which for functional purposes, cannot be guarded.



WARNING indicates a potentially hazardous situation that, if not avoided, could result in death or serious injury. **WARNING** includes hazards that are exposed when safety guards are removed. Warning may also be used to alert against unsafe practices.



CAUTION indicates a potentially hazardous situation that, if not avoided, may result in minor or moderate injury. **CAUTION** may also be used to alert against unsafe practices.

⚠ SHUTDOWN AND STORAGE



AVOID CRUSHING. Make sure all personnel are clear of the implement. Lower implement to the ground, place tractor in park, turn off engine, and remove key.



USE BAR STANDS AND CYLINDER STOPS TO SUPPORT THE IMPLEMENT.

Store implement on a clean, dry, and level surface. An uneven surface could cause implement to shift or fall, resulting in injury or death, as well as implement damage. Securely support all implement components that must be raised. Store implement away from human activity.

⚠ SAFE TRANSPORT

- Engage transport locking devices prior to transport.
- Plan your route to avoid traffic. Yield to traffic in all situations.
- Maximum transport speed is 20 mph (32 kph). Various conditions will require reduced speed. Travel at speeds that allow for adequate control of stopping and steering.



AVOID ELECTROCUTION. Be aware of overhead power lines. Contact or close proximity to power lines can result in injury or death. Use extreme care when operating implement near power lines.



• Know implement transport height and gross weight. Avoid overhead obstructions not allowing your transport height. Do not use bridges rated below combined implement and tractor weight.

• Make sure a slow moving vehicle (SMV) placard is mounted to the implement and is easily visible to other motorists.

• Make allowances for implement size when transporting. Sudden braking can cause a towed load to swerve and/or rollover. Never use independent braking with implement in tow as loss of control and/or rollover can result. Reduce speed if towed implement is not equipped with brakes.



• Do not coast. Always keep tractor or towing device in gear to provide engine braking when traveling downhill.

• Comply with state and local laws governing implement transport.

⚠ WARNING AND SAFETY LIGHTS



• Oversized implements and slow moving vehicles create a hazard when transported on public roads.

• Make sure all warning, safety lights, and turning signals are working and clean. Use safety lighting when using public roads day and night. Replace missing or damaged lights immediately. Comply with state and local laws governing implement safety lighting.

• A safety lighting package, conforming to implement lighting standard ANSI/ASAE S279.12, if not supplied with, is available for addition to your equipment. Contact your Orthman dealer for safety lighting package information. Refer to toolbar operator's manual for safety lighting package installation and adjustment.

⚠️ SAFE OPERATION



READ AND UNDERSTAND THE ENTIRE CONTENT OF THIS MANUAL BEFORE OPERATING OR SERVICING IMPLEMENT. Implement is to be operated by qualified personnel only. Never let children operate implement. A complete understanding of safety precautions, operation, and maintenance is mandatory before implement use.



AVOID ELECTROCUTION. Be aware of overhead power lines. Contact or close proximity to power lines can result in injury or death. Use extreme care when operating implement near power lines.

- Know implement transport height and gross weight. Avoid overhead obstructions not allowing your transport height. Do not use bridges rated below combined implement and tractor weight.



AVOID ROLLOVER. Do not fold or unfold implement and avoid sharp turns when on a hillside, as shift of weight could cause rollover. Operate implement at a safe distance from terrain irregularities and other obstructions that could cause rollover.



AVOID CRUSHING. Make sure all personnel are clear of implement at all times implement is in motion. Be aware of obstructions above, below, and around implement when in operation or transport. Injury or death can result from being struck by the implement.



⚠️ NO RIDERS

NEVER ALLOW RIDERS ON TRACTOR OR IMPLEMENT. Riders hinder operator visibility and can be thrown from the implement and/or be struck by foreign objects resulting in injury or death.

⚠️ PRACTICE SAFE MAINTENANCE



Proper maintenance is your responsibility. Maintenance neglect and/or poor maintenance practices can result in injury or death. Always use the proper tools to maintain implement.

AVOID CRUSHING. Make sure all personnel are clear of the implement. Lower implement to the ground, place tractor in park, turn off engine, and remove key.



USE BAR STANDS AND CYLINDER STOPS TO SUPPORT THE IMPLEMENT.

Store implement on a clean, dry, and level surface. An uneven surface could cause implement to shift or fall, resulting in injury or death, as well as implement damage. Securely support all implement components that must be raised. Store implement away from human activity.



AVOID ENTANGLEMENT. Never lubricate or service implement in motion. Keep away from power driven parts when in motion. Disengage power sources prior to maintaining implement. Injury or death can result from contact with power driven parts when in motion.



AVOID CRUSHING. Do not stand between the tractor and implement when connecting or disconnecting implement. Injury or death can result from being trapped between the tractor and implement.



Escaping pressurized hydraulic fluid can penetrate skin, resulting in injury or death. Relieve hydraulic system pressure before connecting or disconnecting tractor. Use cardboard or wood, **NOT BODY PARTS**, to check for suspected hydraulic leaks. Wear protective gloves and safety glasses or goggles when working with hydraulic systems. If an accident occurs, see a doctor immediately for proper treatment.

⚠ PRACTICE SAFE MAINTENANCE



- Never operate a combustion engine in an enclosed area. Make sure there is adequate ventilation. Exhaust fumes can cause asphyxiation.



- Service tires safely. Tire and rim separation can result in serious injury or death. Do not over inflate tires. Only mount or dismount tires if you possess the proper equipment, otherwise contact a trained professional. Always maintain correct tire pressure. Inspect tires and wheels daily. Do not operate tires with inadequate pressure, cuts, visible damage, or missing hardware.



- Be extremely careful working around unshielded sharp edges. Injury may result from contact with sharp edges.
- Keep all parts in good condition and properly installed. Replace damaged or missing parts immediately.
- Remove tools and unused parts prior to implement operation.

⚠ PREPARE FOR EMERGENCIES



- Be prepared for a fire. Keep a readily accessible fire extinguisher at all times.
- Keep a readily accessible stocked first aid kit and emergency phone numbers for your doctor, hospital, ambulance, and fire department.
- Wear protective clothing and equipment. Wear clothing appropriate for the situation. Protect your eyes, ears, hands, and feet with the use of protective goggles, ear plugs, gloves, boots, etc.

⚠ ANHYDROUS AMMONIA - NH₃ LIQUID FERTILIZER



ANHYDROUS AMMONIA (NH₃) AND LIQUID FERTILIZER APPEARS HARMLESS. DIRECT EXPOSURE TO NH₃ OR LIQUID FERTILIZER IS EXTREMELY DANGEROUS AND CAN RESULT IN INJURY AND/OR DEATH.

- Keep a clean supply of water readily accessible in case of exposure to NH₃ or liquid fertilizer.
- Wear protective goggles and gloves when working with NH₃ or liquid fertilizer. Be sure all persons involved in the operation are properly trained concerning the dangers and precautions involved in the application of NH₃ or liquid fertilizer.
- If you choose to apply NH₃ or liquid fertilizer, it is advisable to consult documented information regarding safe handling and application of NH₃ or liquid fertilizer. Information is available from the following recognized sources:

1. American National Standards Institute - www.ansi.org - (212) 642-4900
2. Material Safety Data Sheets - MSDS - www.msdsonline.com
3. National Safety Council - www.nsc.org/necas
4. The Fertilizer Institute - www.tfi.org
5. United States Department of Transportation - D.O.T. - www.dot.gov
6. Compressed Gas Association - www.cganet.com



⚠ SAFETY NEVER HURTS

READ AND UNDERSTAND THE ENTIRE CONTENT OF THIS MANUAL BEFORE OPERATING OR SERVICING IMPLEMENT.

- Understand all implement functions.
- Never stand between tractor and implement when connecting or disconnecting implement.
- Be aware of all surroundings before moving implement.
- Operate implement from operator's seat only.
- Never mount or dismount a moving tractor.
- Never leave engine running when implement is unattended.
- Keep away from power driven parts when in motion.
- Make sure all personnel are clear before lowering implement to the ground.

DANGER

RED

WARNING

ORANGE

CAUTION

YELLOW

SAFETY DECALS

Safety decals promote awareness and knowledge concerning safe operation and maintenance of the implement.

Carefully **READ ALL SAFETY DECALS** in this manual as well as on the implement. Keep implement clean so decals are easily visible. Keep all decals in good and legible condition. Immediately replace damaged and/or missing decals. Replacement decals are available from your Orthman dealer.

To install decals: Thoroughly clean area where decal is to be placed and attach decal void of bubbles. Refer to this safety information section for proper decal placement.

IMPORTANT

Equipment operators should understand the enclosed manual before operating this equipment. Replacement manual, call 308-324-4654

Orthman Mfg., Inc. - 75765 Rd. 435 - Lexington, NE 68850 153-101

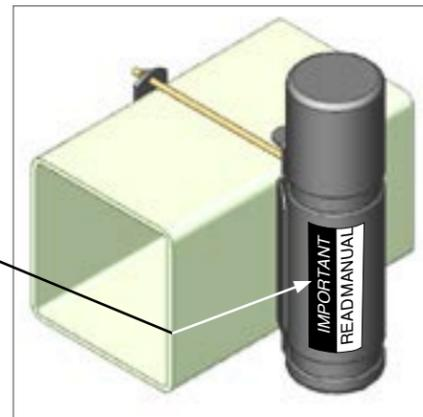

MANUAL ENCLOSURE

CAUTION

1. Read and understand all operator manuals before implement use.
2. Follow all tractor or towing device operating procedures and safety guidelines.
3. Do not allow riders on implement.
4. Lower implement to the ground, place tractor in park, turn off engine, and remove key. Wait for all moving parts to come to a complete stop before working on implement.
5. Be extremely careful working around unshielded sharp edges.
6. Make sure all safety lighting and decals are clean. Use hazard lights when in transport.
7. Engage all safety devices before transporting or working beneath implement.
8. Contact or close proximity to power lines can result in electrocution.
9. Review all safety instructions with all operators on a frequent basis.

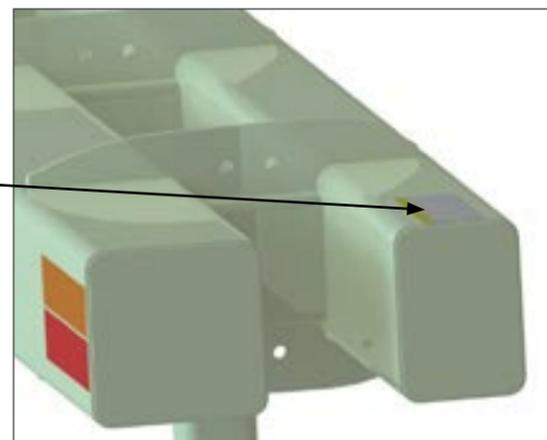

END OF WING

SAFETY DECALS

WARNING

1. Stay clear of wing sections when raising and lowering.
2. Engage all transport locking devices prior to transport. (see operator's manual)
3. Use extreme caution when in transport. Be aware of overhead power lines and any other obstructions.
4. Reduce speed as raised implement reduces tractor maneuverability.

153-013

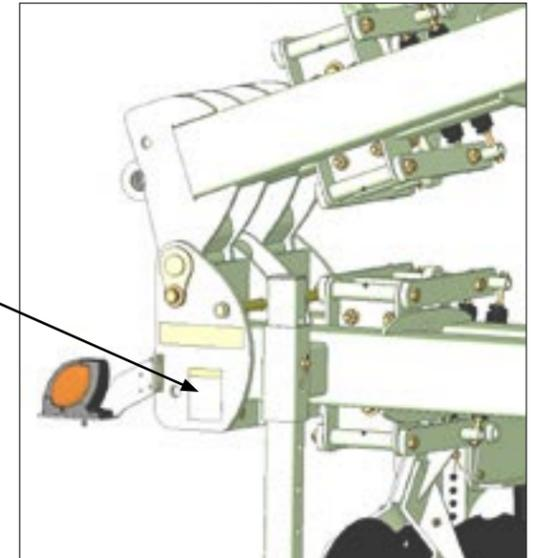

FRONT OF HINGE

	<p>DANGER</p>
	<p>HIGH-PRESSURE FLUID HAZARD</p> <p>To prevent serious injury or death:</p> <ul style="list-style-type: none"> • Relieve pressure on hydraulic system before servicing or disconnecting hoses. • Wear proper hand and eye protection when searching for leaks. Use wood or cardboard instead of hands. • Keep all components in good repair.

153-528

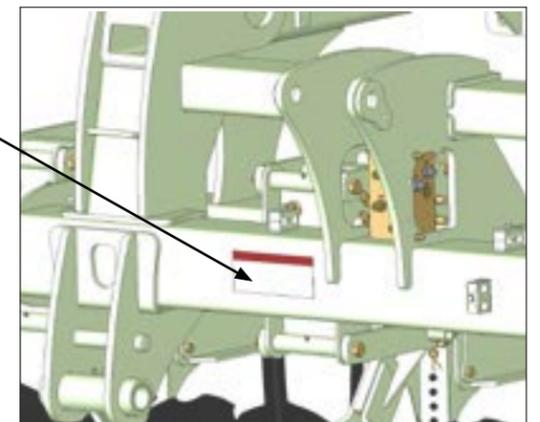

FRONT CENTER OF BAR

SAFETY DECALS

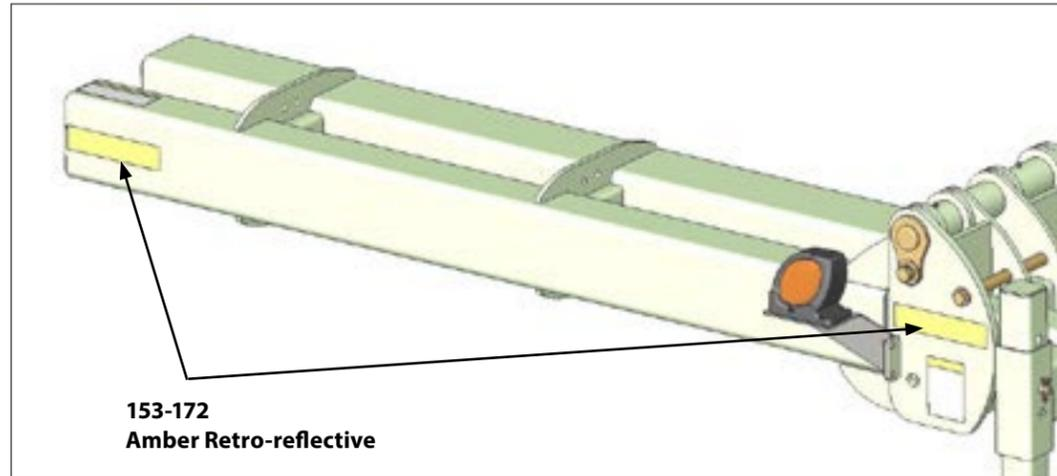

153-172
Amber Retro-reflective

FRONT OF TOOLBAR, END OF WING, END OF CENTER SECTION

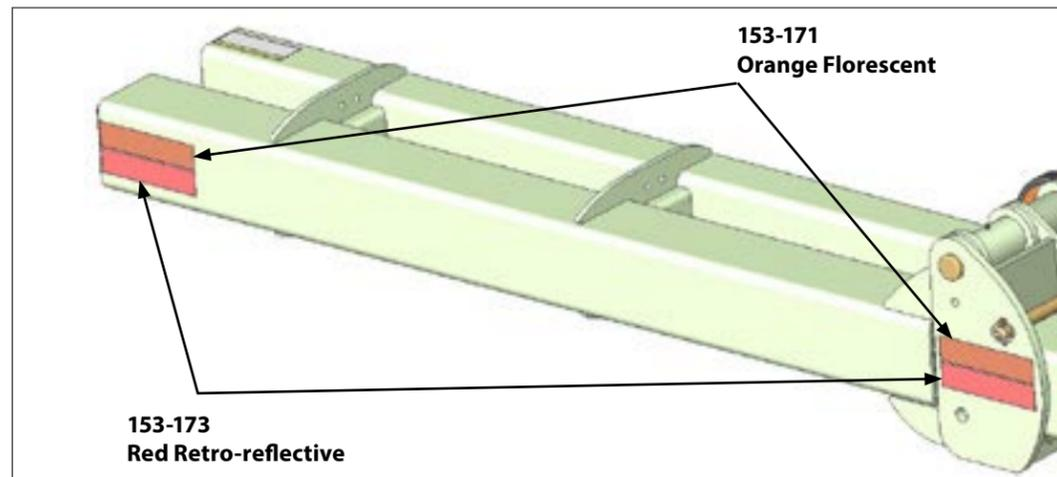

153-173
Red Retro-reflective

153-171
Orange Florescent

REAR OF TOOLBAR, END OF WING, END OF CENTER SECTION

SAFETY DECALS



153-173
Red Retro-reflective

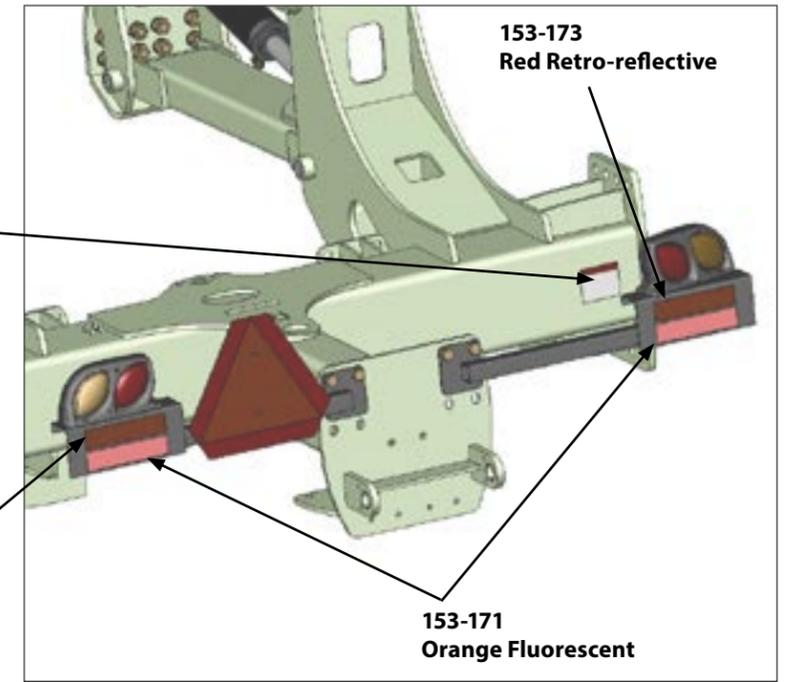

153-173
Red Retro-reflective

153-171
Orange Fluorescent

REAR OF CARRIER

153-173
Red Retro-reflective

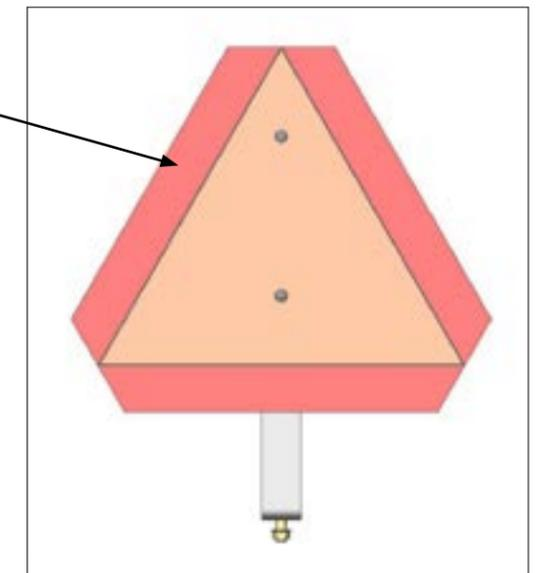

SMV SIGN

ORTHMAN DECALS



153-430

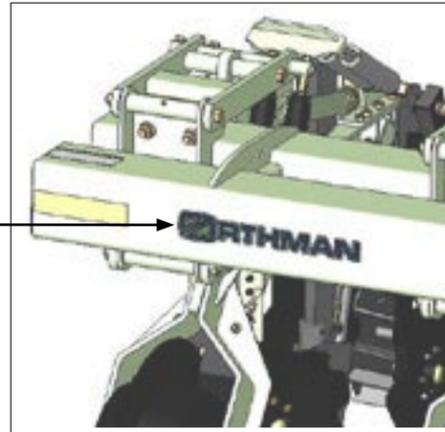

RIGHT FRONT AND LEFT REAR OF TOOLBAR

ORTHMAN SERIAL TAG

The Orthman serial tag contains valuable information. The model and serial numbers provide Orthman dealers and the Orthman Service Department with the exact specifications of your implement if any warranty or service issues need to be addressed.



153-011

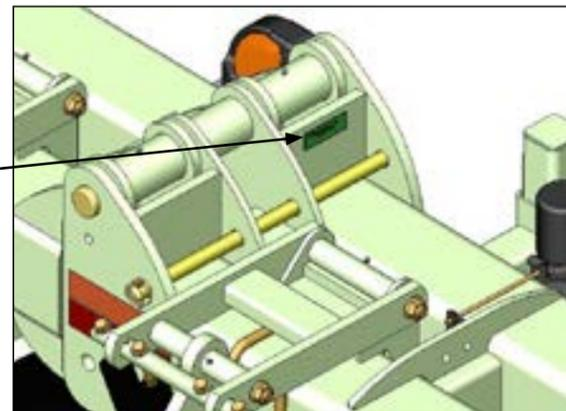

LEFT TOOLBAR HINGE

TOOLBAR COMPONENT IDENTIFICATION

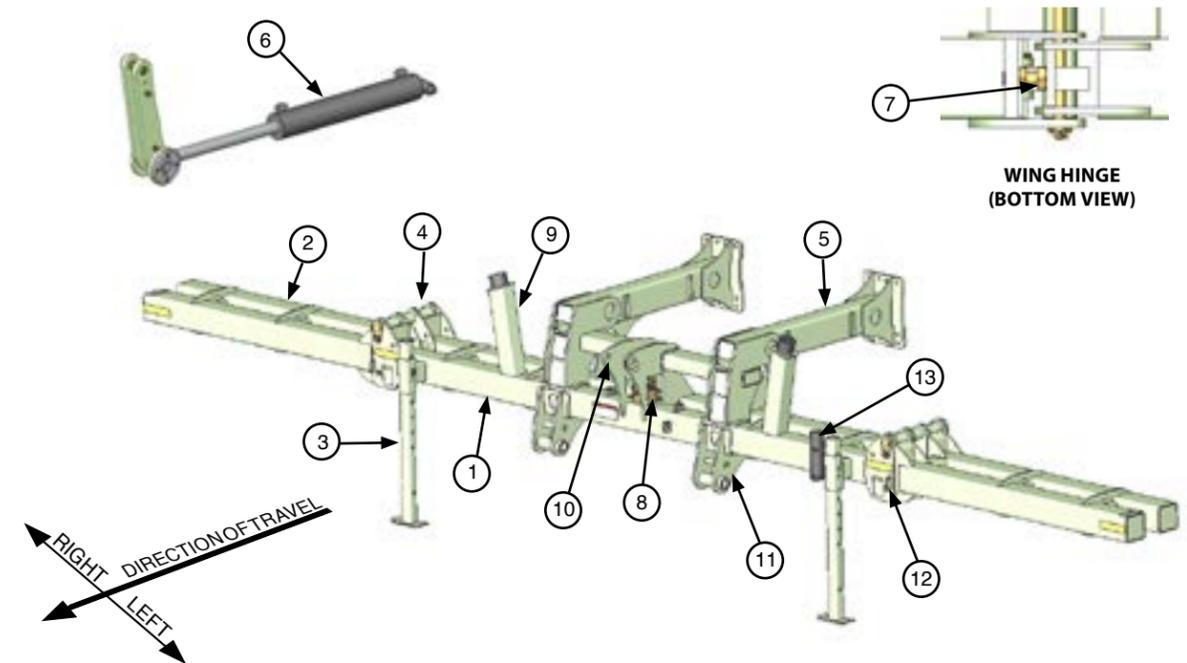

WING HINGE (BOTTOM VIEW)

NOTE: Right and left as illustrated above and referenced from this point on, is determined by facing the same direction the toolbar will travel while in use.

- 1. CENTER SECTION.** A solid, heavy-duty center section provides a robust toolbar foundation.
- 2. WINGS.** Dual tube wings provide strength to the very end of the toolbar.
- 3. BAR STANDS.** Support machine frontal weight during storage and maintenance.
- 4. TOOLBAR WING HINGE.** Fold point of the toolbar wings.
- 5. CARRIER STRINGER.** Connects the toolbar to the carrier and is designed to allow for easy access to row units beneath.
- 6. INTERNAL CYLINDER ASSEMBLY.** Hydraulic cylinder is seated inside the toolbar and extends to fold the wing and retracts to unfold the wing. Some larger toolbars will utilize two cylinder assemblies to fold each wing, tied together with a hydraulic manifold.
- 7. WING LEVEL BOLTS.** These bolts serve as the down-stop for the wing and can be fine-tuned to accurately level the bar when unfolded.
- 8. HYDRAULIC MANIFOLD.** Directs hydraulic fluid to the proper cylinders per specific function.
- 9. WING RESTS.** Welded on wing rests for wing support during transport and storage.
- 10. TOP LINK CENTER MAST PLATES.** Connection point between tongue top link and toolbar.
- 11. LOWER HITCH TUGS.** Connection point between lower hitch clamps on tongue and toolbar.
- 12. RIGID WING LOCK PIN.** Use this pin to lock down the toolbar to a rigid machine. When not in use, storage for these pins are at the end of the center section near the hinge pin.
- 13. MANUAL STORAGE TUBE.** A place to safely store this manual, and will also house the manual for any row unit that is on the toolbar if you purchased a full machine.

**NARROW TRANSPORT (NT)
TOOLBAR
COMPONENT IDENTIFICATION**

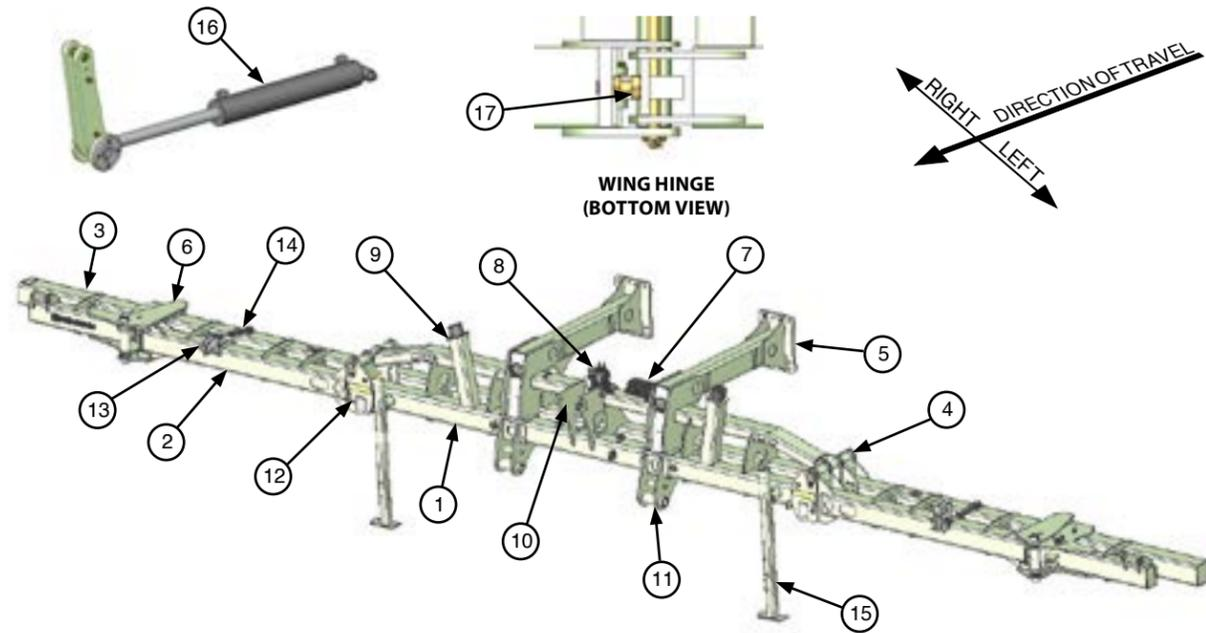

NOTE: Right and left as illustrated above and referenced from this point on, is determined by facing the same direction the toolbar will travel while in use.

- 1. CENTER SECTION.** A solid, heavy-duty center section provides a robust toolbar foundation.
- 2. MID WING.** Dual tube wings provide strength to the very end of the toolbar.
- 3. OUTER WING.** Revolves inward against the mid wing before the mid wings fold vertically.
- 4. TOOLBAR MID WING HINGE.** Fold point of the toolbar mid wings.
- 5. CARRIER STRINGER.** Connects the toolbar to the carrier and is designed to allow for easy access to row units beneath.
- 6. OUTER WING HINGE.** Fold point of the outer wings.
- 7. HYDRAULIC FLOW GEAR DIVIDER.** Directs oil to the outer wing fold hydraulic cylinders first, and then to the mid wing internal cylinders during folding.
- 8. HYDRAULIC MANIFOLD.** Directs hydraulic fluid to the proper cylinders per specific function.
- 9. WING RESTS.** Welded on wing rests for wing support during transport and storage.
- 10. TOP LINK CENTER MAST PLATES.** Connection point between tongue top link and toolbar.
- 11. LOWER HITCH TUGS.** Connection point between lower hitch clamps on tongue and toolbar.
- 12. RIGID WING LOCK PIN.** Use this pin to lock down the toolbar to a rigid machine. When not in use, storage for these pins are at the end of the center section near the hinge pin.
- 13. OUTER WING LATCH.** Mechanism to lock the outer wings in place when folded against the mid wing.
- 14. OUTER WING LATCH HYDRAULIC CYLINDER.** Hydraulic cylinder used to perform the action of locking the outer wings in place when folded.
- 15. BAR STANDS.** Support machine frontal weight during storage and maintenance.
- 16. INTERNAL CYLINDER ASSEMBLY.** Hydraulic cylinder is seated inside the toolbar and extends to fold the wing and retracts to unfold the wing. Some larger toolbars will utilize two cylinder assemblies to fold each wing, tied together with a hydraulic manifold.
- 17. WING LEVEL BOLTS.** These bolts serve as the down-stop for the wing and can be fine-tuned to accurately level the bar when unfolded.

**TONGUE
COMPONENT IDENTIFICATION**

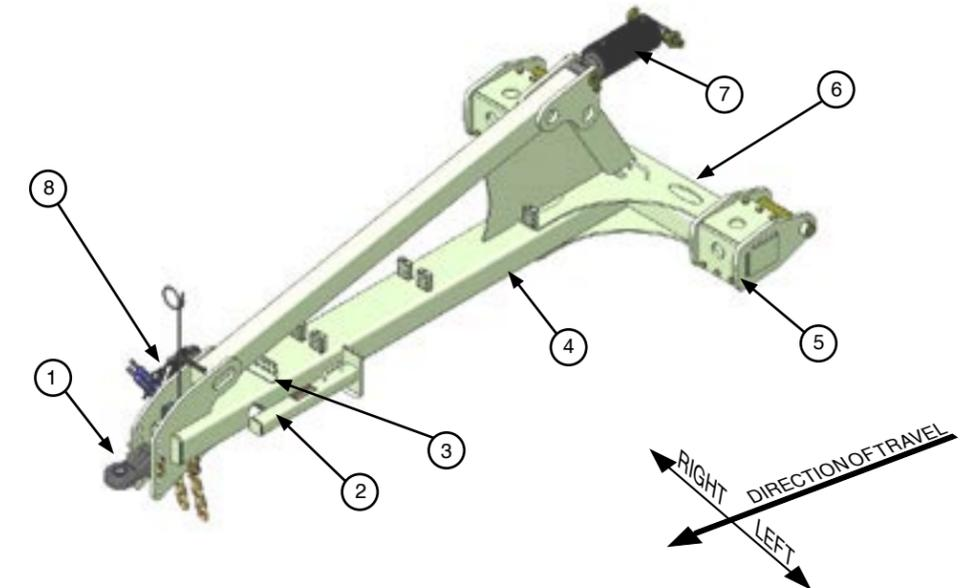

NOTE: Right and left as illustrated above and referenced from this point on, is determined by facing the same direction the toolbar will travel while in use.

- 1. TRACTOR HITCH TAB.** Socket swivel tab eliminates hitch pin fore and aft movement.
- 2. TONGUE BAR STAND.** Keeps the tongue from resting on the ground, but does not support machine weight. Always use bar stands to support machine.
- 3. HYDRAULIC LINE BULK-HEAD.** For assembly ease, and in case of damaged hoses, the hydraulic lines for the 1tRIPr[®] XD are all routed to an organized front bulkhead where they terminate and separate hydraulic hoses make their way to the tractor.
- 4. TONGUE FRAME.** T-shape design offers excellent strength and good turning radius.
- 5. HITCH MODULES.** Line-bored connections for increased strength and durability.
- 6. HITCH CROSS BAR.** 5" x 7" bar to support hitch modules.
- 7. LIFT CYLINDER.** 6" bore cylinder powers the front lift of the implement.
- 8. COURTESY PALETTE.** Designed to offer the convenience of hydraulic hose storage while the machine is not in use. Also serves as the mounting location for the safety lights logic module.

CARRIER COMPONENT IDENTIFICATION

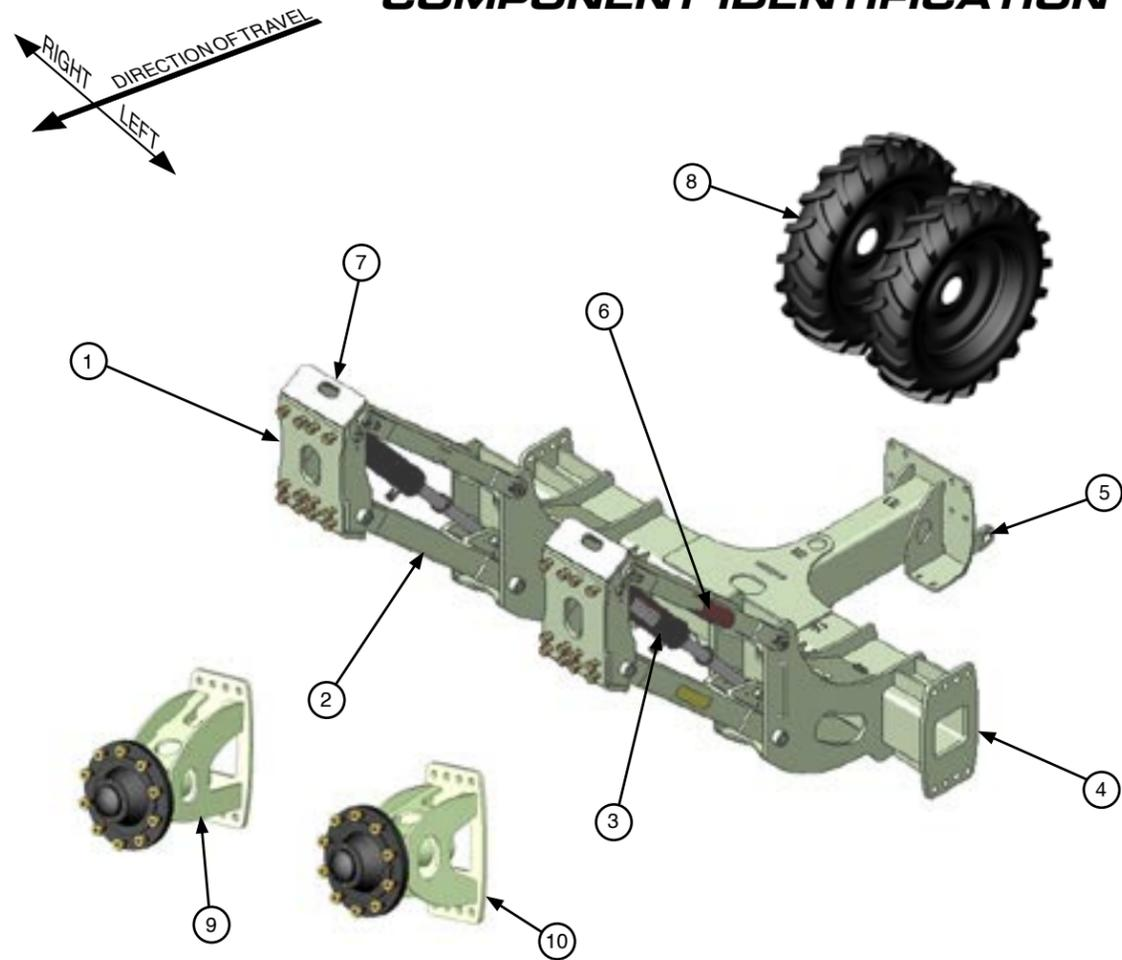

NOTE: Right and left as illustrated above and referenced from this point on, is determined by facing the same direction the toolbar will travel while in use.

- 1. FRAME CONNECTION PLATE.** Area of connection between toolbar stringers and carrier lift arms.
- 2. LIFT ARM.** Combines strength and the versatility to raise and lower the machine.
- 3. HYDRAULIC LIFT CYLINDER.** Lift and lower the machine.
- 4. WHEEL SPINDLE CONNECTION PLATE.** Area of connection between wheel spindle and carrier.
- 5. OPTIONAL NURSE TANK HITCH MOUNT.** Allows for the ability to tow a nurse tank for more nutrient application capabilities.
- 6. SAFETY TRANSPORT LOCK.** When machine is lifted, this bracket is fitted around the hydraulic cylinder rod to prevent machine from making ground contact if a rare instance of hydraulic failure occurs.
- 7. CARRIER ARM LIFT HANDLE.** Handle designed to ease the assembly of the machine by provided a point to mount lifting devices.
- 8. CARRIER WHEELS.** Available in sizes 14.9R46 and 480/80R50.
- 9. 14.9R46 WHEELSPINDLE.** Spindles used in conjunction with 14.9R46 size tires.
- 10. 480/80R50 WHEEL SPINDLE.** Spindles used in conjunction with 480/80R50 size tires.

LIGHT KIT COMPONENT IDENTIFICATION

An un-assembled light kit will come with 1tRiPr® XD. The light kit will come in a box that has Orthman manufactured components in it, as well as an ag light kit from COBO light company. Below is an example of what will typically be found in a light kit. For installation instructions, refer to the 1tRiPr® XD pre-delivery manual.

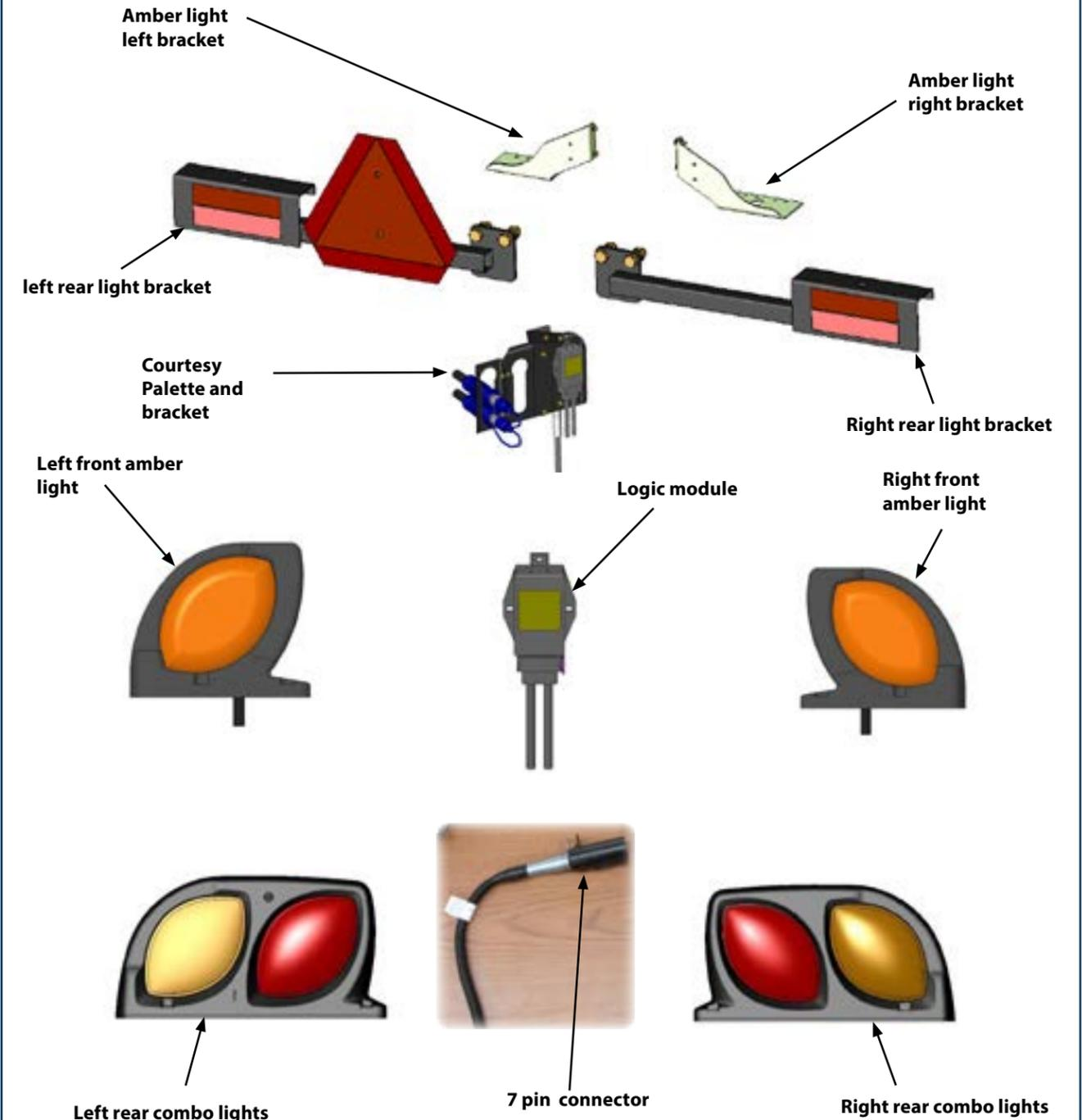

Left rear combo lights

7 pin connector

Right rear combo lights

SHIPPING CONFIGURATION

The majority of the *1tRIPr[®] XD* is assembled at Orthman Mfg., Inc. The *1tRIPr[®] XD* is assembled in an appropriate shipping configuration to ensure transport safety and efficiency from the manufacturer.
Unfolded Shipping Configuration

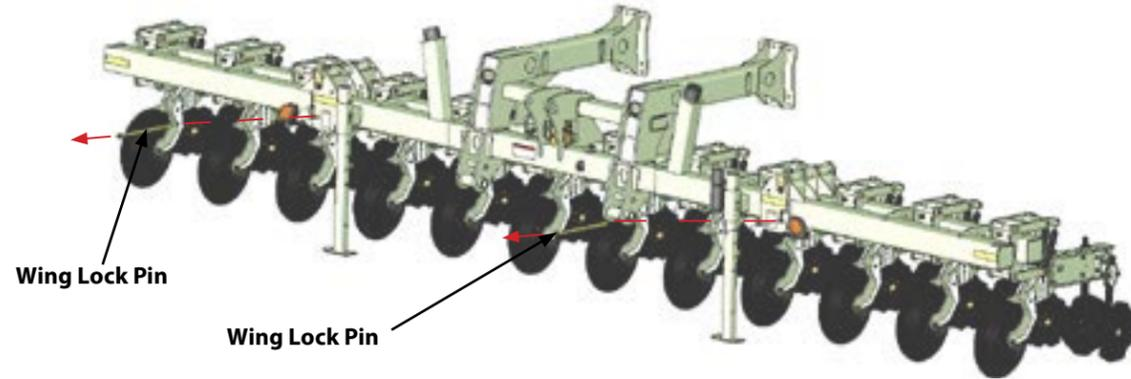

Wing Lock Pin

Wing Lock Pin

Folded Shipping Configuration

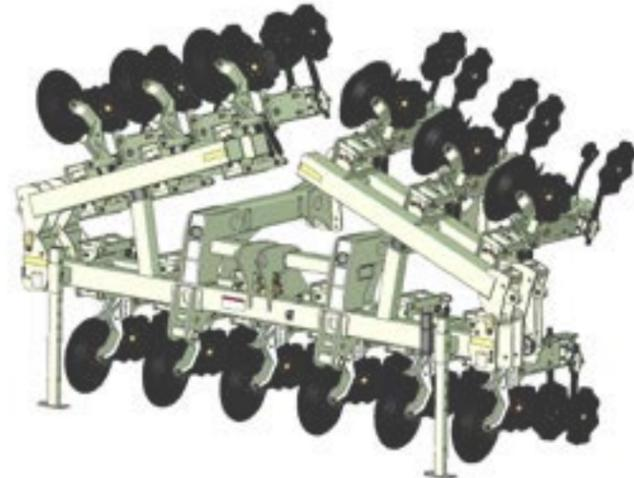

The *1tRIPr[®] XD* may ship folded or unfolded, depending on configurations. If the toolbar ships unfolded (shown picture above) it will most likely have the rigid wing lock pins installed. These pins will need to be removed prior to folding the toolbar. (see pg. 6 - 1)

The *1tRIPr[®] XD* will also come from the factory without the safety lights or the SMV installed, due to the potential for damage to those items during shipment. These items will also need to be installed prior to use or transport of the *1tRIPr[®] XD*.



CAUTION! BE EXTREMELY CAREFUL WORKING AROUND UNSHIELDED SHARP EDGES. INJURY MAY RESULT FROM CONTACT WITH SHARP EDGES.

PREPARING THE MACHINE



Tooling options available for added *1tRIPr[®] XD* versatility are illustrated and explained in the tooling options section of this manual. Field adjustments are illustrated and explained in the field settings section of this manual.

Tooling options available for the *1tRIPr[®]* row units are illustrated and explained in the tooling options section of the *1tRIPr[®]* operator's manual.



Before each use, check hardware for wear and proper torque. Replace damaged or missing hardware with hardware of an identical grade to restore implement to original specifications.

MACHINE TO TRACTOR CONNECTION



AVOID CRUSHING. Do not stand between tractor and implement when connecting or disconnecting implement. Injury or death can result from being trapped between the tractor and implement.

AVOID CRUSHING. Make sure all personnel are clear of the implement. Lower implement to the ground, place tractor in park, turn off engine, and remove key.



USE BAR STANDS TO SUPPORT THE IMPLEMENT. Park implement on a clean, dry, and level surface. An uneven surface could cause implement to shift or fall, resulting in injury or death, as well as implement damage. Securely support all implement components that must be raised.

CONNECT TRACTOR DRAWBAR TO XD TONGUE TAB:

1. Position the rear of the tractor in front of the tongue tab on the XD tongue.
2. Connect machine lift hydraulic hoses to a tractor hydraulic SCV remote to enable the tongue to raise up or lower down to align the XD tongue tab with the tractor drawbar.
3. Move tractor into the position that will enable the hitch pin to be inserted through both the tractor drawbar and XD tongue tab.
4. Place tractor in park.
5. Insert hitch pin



CAUTION! Escaping pressurized hydraulic fluid can penetrate skin, resulting in injury or death. Relieve hydraulic system pressure before connecting or disconnecting tractor. Use cardboard or wood, **NOT BODY PARTS**, to check for suspected hydraulic leaks. Wear protective gloves and safety glasses or goggles when working with hydraulic systems. If an accident occurs, see a doctor immediately for proper treatment.

MACHINE TO TRACTOR CONNECTION (CONTINUED)



⚠ DANGER! Escaping pressurized hydraulic fluid can penetrate skin, resulting in injury or death. Relieve hydraulic system pressure before connecting or disconnecting tractor. Use cardboard or wood, **NOT BODY PARTS**, to check for suspected hydraulic leaks. Wear protective gloves and safety glasses or goggles when working with hydraulic systems. If an accident occurs, see a doctor immediately for proper treatment.

CONNECT HYDRAULIC HOSES TO TRACTOR:

1. Four (4) hydraulic hoses are located on the machine tongue. Two (2) hoses possess blue colored handles. Two (2) hoses possess green colored handles. The hoses with blue handles are the wing fold hoses. The hoses with green handles are the machine lift and lower hoses.
2. Each hose also possesses an “extend” symbol or a “retract” symbol. (See illustration) Connect the “extend” labeled hoses to the pressure port of a tractor SCV remote. Connect the “retract” labeled hoses to the retract port of a corresponding tractor SCV remote.

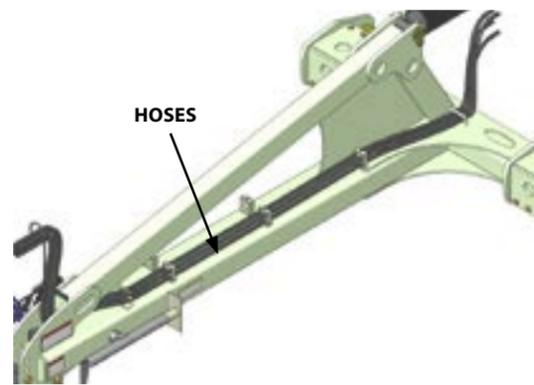

MACHINE TONGUE

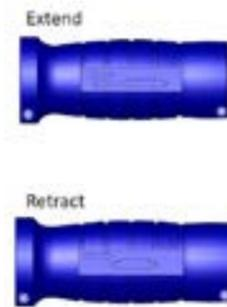

HOSE SYMBOL IDENTIFICATION

TONGUE TAB

The *1tRIPr*® XD comes standard with a Category 3/Category 4 tongue tab (152-806) with an insert for a 1 1/2” tractor hitch pin size (Cat. 3) and an additional tab insert for a 2” (5.08 cm) tractor hitch pin size (Cat 4), which can replace the Category 3 tab insert by removal of the snap ring above the tab insert and then removing the tab insert from the internal socket. Also available is a Category 5 tongue tab (152-805) with a tab insert for a 2 3/4” (6.99 cm) tractor hitch pin size. These tongue tabs have an internal socket that fits the pin closely. This eliminates implement backlash and improves control.

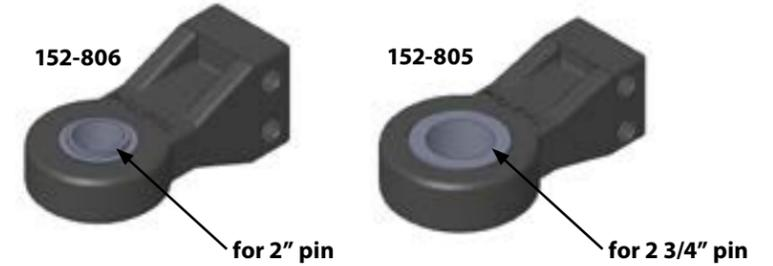

MOUNTING OF TONGUE TAB



⚠ AVOID CRUSHING. Make sure all personnel are clear of the implement. Lower implement to the ground, place tractor in park, turn off engine, and remove key.

USE BAR STANDS TO SUPPORT THE IMPLEMENT. Park implement on a clean, dry, and level surface. An uneven surface could cause implement to shift or fall, resulting in personal injury or death, as well as implement damage. Securely support all implement components that must be raised. Remove buildup of grease, oil, or debris prior to installing row unit mounts.

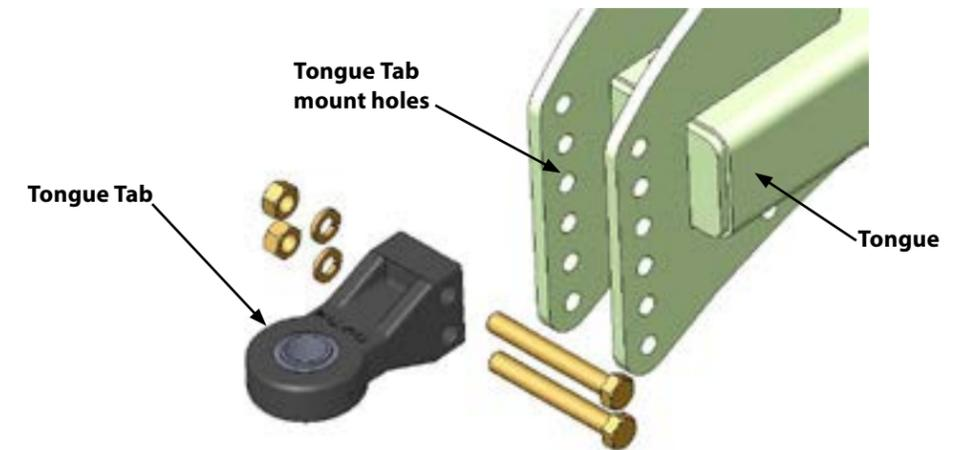

1. Determine level mounting location. See page 6 - 4. Tractor drawbar heights vary.
2. Insert Tongue Tab in-between Tongue Tab mountin plates on Tongue.
3. Align bolts in correct holes, and fasten using nuts and lockwashers.
4. After tightening, tongue tab mount plates should clamp tight on Tongue tab. If gap exists it may be necessary to shim inside with a flat or machined washer.

NOTE: IT IS IMPORTANT THAT THE TONGUE TAB MOUNT PLATES CLAMP TIGHT ON THE TONGUE TAB. **RECOMMENDED TOOLS:** IMPACT WRENCH, 1 1/2” IMPACT SOCKET, 1 1/2” END WRENCH.

FERTILIZER PACKAGES

The 1tRIPr[®] XD toolbar may be equipped with a variety of nutrient application systems. These application systems may be ordered as a package containing mounting brackets, a holding tank, and other package specific components. Available packages are as follows:

LIQUID FERTILIZER PACKAGE:

The liquid fertilizer package combines precision nutrient placement with more than adequate liquid hauling capacity. The package includes a 1,000 gallon tank, and tank mounts. Pumps, hoses, and other wetware are not included. Components of the liquid fertilizer package are listed and illustrated below:

1. RIGHT REAR TANK MOUNT
2. LEFT REAR TANK MOUNT
3. RIGHT FRONT TANK MOUNT
4. LEFT FRONT TANK MOUNT
5. HARDWARE
6. 1,000 GALLON TANK

For installation instructions of the liquid fertilizer package, refer to the 1tRIPr[®] XD Pre-Delivery Manual.

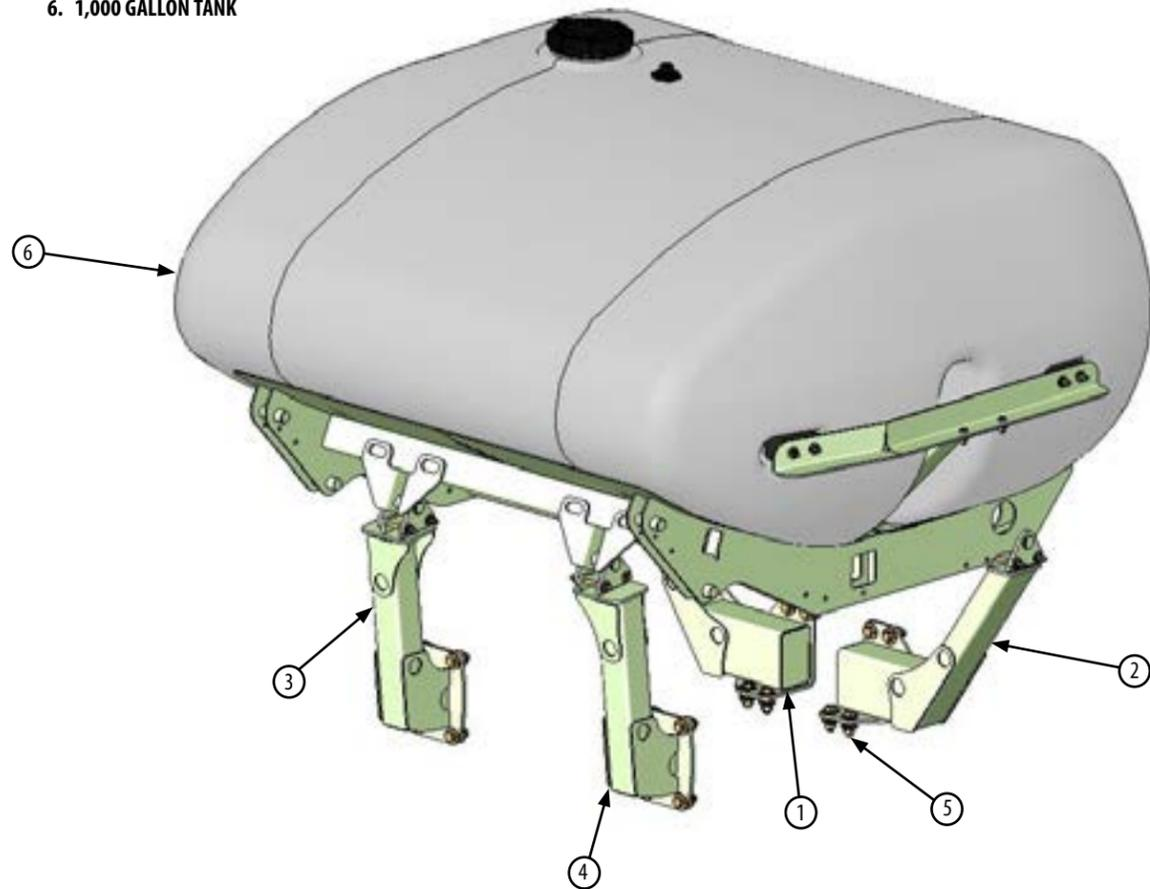

FERTILIZER PACKAGES

DRY FERTILIZER PACKAGE:

The dry fertilizer package combines the precision nutrient placement of the Orthman 1tRIPr[®] and the proven dry fertilizer delivery system from Montag Mfg. The package includes a 6 or 9 ton dry holding tank and cradle, tank mounts and routing brackets, the Montag meter assembly air release brackets and hardware, encoder, air hose, hose clamps, and hydraulic hoses. The control system is not included, but compatible systems include Raven 660, MicroTank GSC-1000, and John Deere GS Dry Rate Controller. Components of the dry fertilizer package are listed and illustrated below:

1. RIGHT REAR TANK MOUNT
2. LEFT REAR TANK MOUNT
3. RIGHT FRONT TANK MOUNT
4. LEFT FRONT TANK MOUNT
5. HARDWARE AND HOSE BRACKETRY
6. TANK AND TANK CRADLE ASSEMBLY

For installation instructions of the dry fertilizer package, refer to the 1tRIPr[®] XD Pre-Delivery Manual.

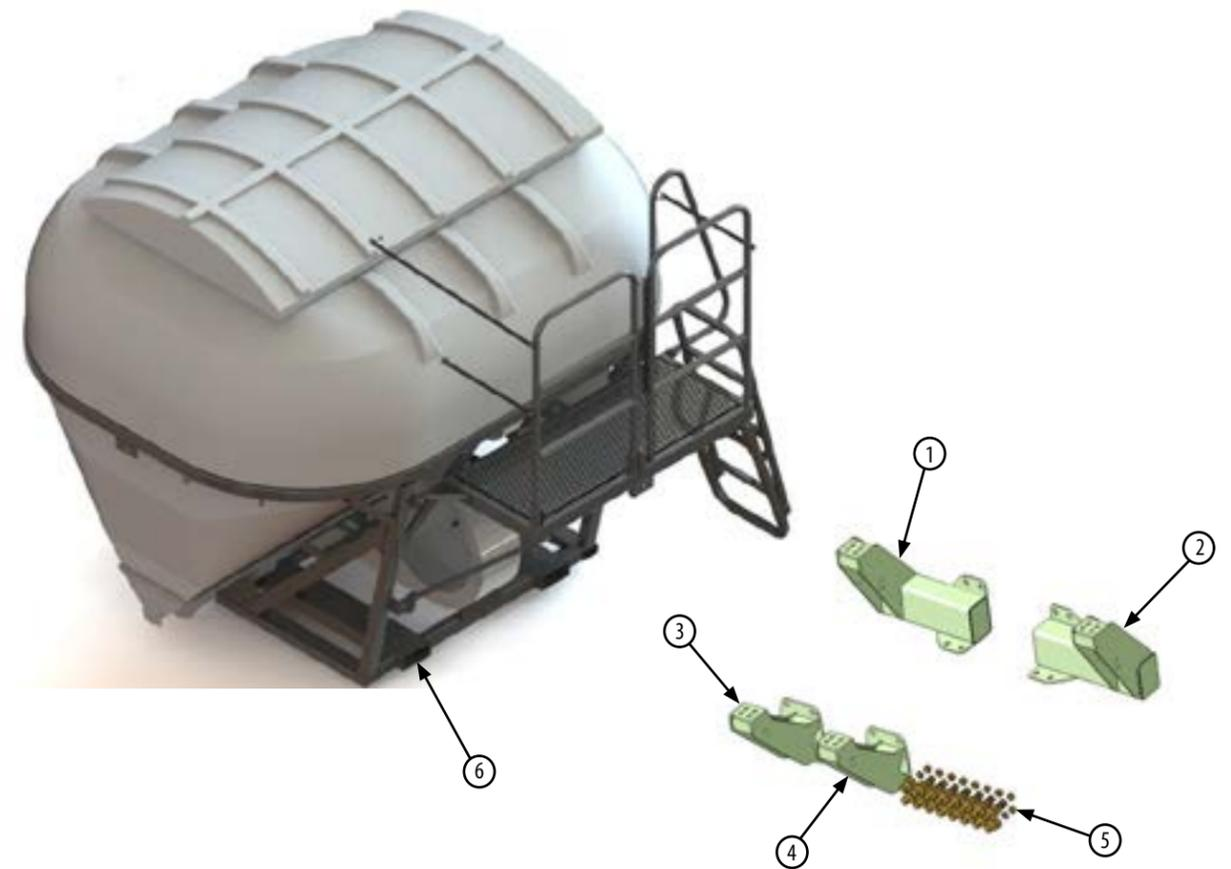

ADDITIONAL OPTIONS

SCALE KIT OPTION:

For use only on dry tank packages, a scale kit is available to monitor tank capacity at all times through the field. The scale kit load cells replace the mount plates on the carrier tank mounts. Scale kit wiring harness is then fastened to the carrier and toolbar as it is strung to the tractor cab. **For installation instructions of the scale kit, refer to the 1tRIPr[®] XD Pre-Delivery Manual.**



NURSE TANK HITCH OPTION:

A nurse tank hitch is available for use in conjunction with both the dry and liquid fertilizer packages. The hitch attaches to the rear of the carrier. **For installation instructions of the nurse tank hitch, refer to the 1tRIPr[®] XD Pre-Delivery Manual.** Components of the nurse tank hitch package are listed and illustrated below:

- 1. NURSE TANK HITCH
- 2. HITCH PIN
- 3. DROP LIMITING BUMPERS
- 4. BUMPER MOUNTING HARDWARE

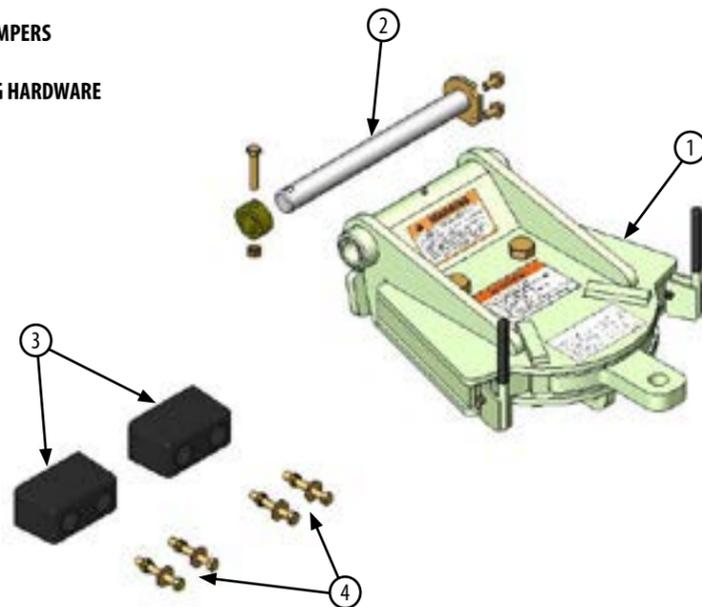

GPS GUIDED STEERING SYSTEM

Your Orthman 1tRIPr[®] XD may be equipped with a GPS guided steering system called Smart Implement Guidance. This system is compatible with both John Deere and Trimble GPS guidance systems. To upgrade your 1tRIPr[®] XD to a Smart Implement Guidance system, contact your local Orthman dealer.

COMPONENT IDENTIFICATION

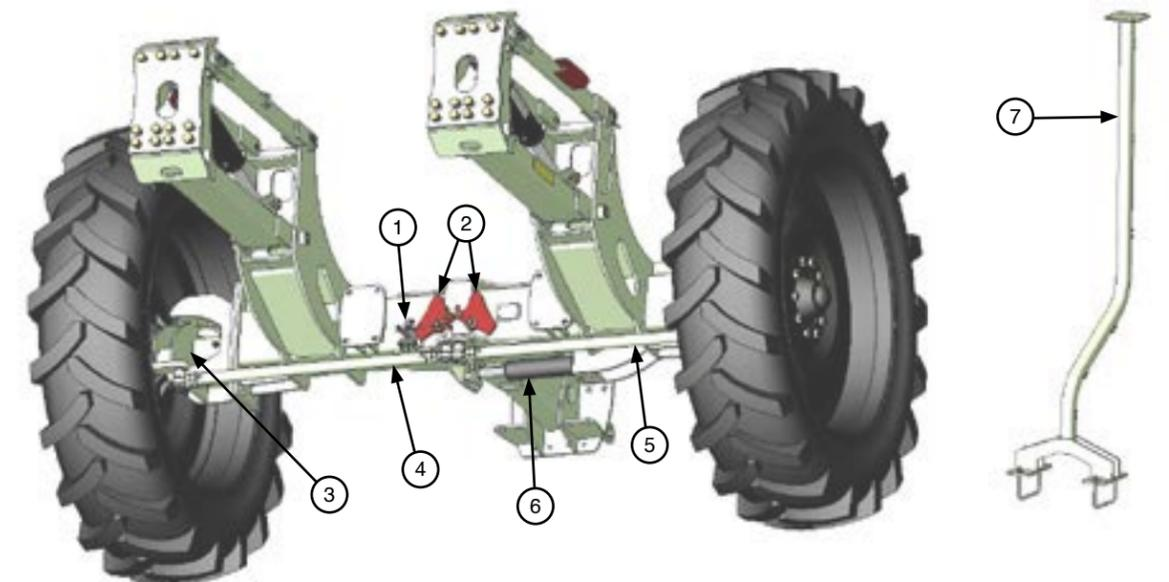

- 1. **IMPLEMENT FEEDBACK SENSOR.** Sends position information of the wheels to the GPS controller.
- 2. **TRANSPORT SAFETY LOCKS.** Prevents any steering action to occur during transport of machine.
- 3. **STEERABLE AXLE KNUCKLE.** Rotating knuckle connected to the steering hydraulic cylinder by each strut.
- 4. **RIGHT STRUT.** Connection between the axle knuckle and steering hydraulic cylinder.
- 5. **LEFT STRUT.** Connection between the axle knuckle and steering hydraulic cylinder.
- 6. **STEERING HYDRAULIC CYLINDER.** Actuates the steerable axle knuckles.
- 7. **GPS RECEIVER TOWER.** Mounting location for the GPS receiver onto the machine.

PREPARATION AND SET UP

Before using the Smart Implement Guidance system, be sure to read and understand the John Deere or Trimble guidance system operator's manual. Only a trained technician should install and repair the guidance system. Once at the field, perform the following steps to prepare your guidance system for field use.



AVOID CRUSHING. Make sure all personnel are clear of the implement and the wheels before calibrated guidance system.



DANGER! Escaping pressurized hydraulic fluid can penetrate skin, resulting in injury or death. Relieve hydraulic system pressure before connecting or disconnecting tractor. Use cardboard or wood, **NOT BODY PARTS**, to check for suspected hydraulic leaks. Wear protective gloves and safety glasses or goggles when working with hydraulic systems. If an accident occurs, see a doctor immediately for proper treatment.

PREPARATION FOR USE

1. Hook up steering hydraulic cylinder hydraulic hoses to a tractor SCV remote port. See pg. 5 - 6 for routing.
2. Hook up all guidance system related components according to the guidance system's operator's manual. Route wiring along the GPS receiver tower and the machine in a clean and neat manner and fasten every 6".
3. Place transport safety locks in the 'unlocked' position by removing each pin and rotating the plate outward. Replace each pin once holes are lined up.

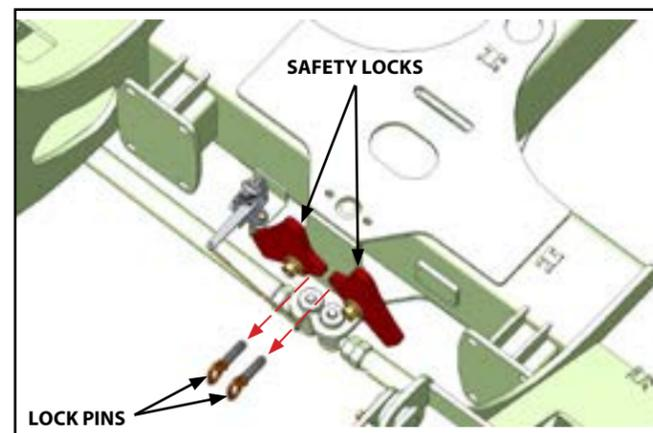

4. Read and understand your guidance system's operator's manual before performing calibration and using the system. Be sure all electrical connections are installed and fastened away from moving parts.

5. Calibrate the system by performing the calibration steps on the following pages.

**PREPARATION AND SET UP
(CONTINUED)**



AVOID CRUSHING. Make sure all personnel are clear of the implement and the wheels before calibrated guidance system.



DANGER! Escaping pressurized hydraulic fluid can penetrate skin, resulting in injury or death. Relieve hydraulic system pressure before connecting or disconnecting tractor. Use cardboard or wood, **NOT BODY PARTS**, to check for suspected hydraulic leaks. Wear protective gloves and safety glasses or goggles when working with hydraulic systems. If an accident occurs, see a doctor immediately for proper treatment.

CALIBRATION

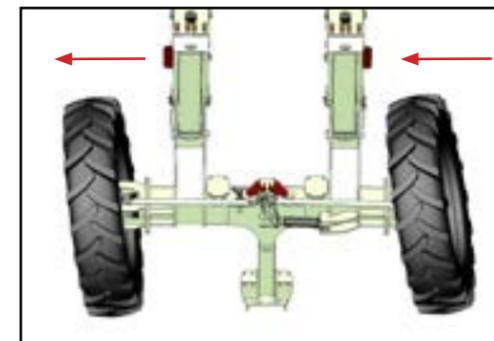

FULLY RETRACTING CYLINDER

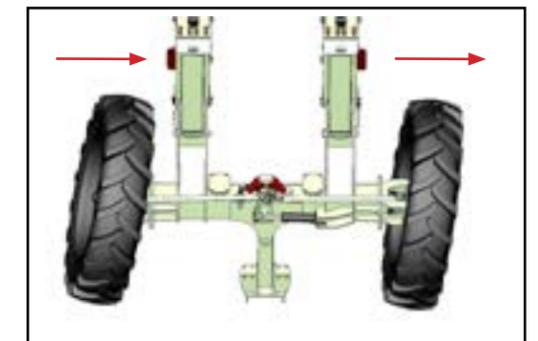

FULLY EXTENDING CYLINDER

IMPORTANT! DO NOT MANUALLY OPERATE STEERING COMPONENTS WITH SAFETY LOCKS IN THE LOCKED POSITION AS DAMAGE WILL OCCUR.

1. Begin by fully steering the wheels in both directions several times to purge out any air that may be in the hydraulic lines. This can be accomplished by:

A. If using a John Deere guidance system, cycle the tractor SCV lever that corresponds with the steering hydraulic cylinder.

B. If using a Trimble guidance system, place the tractor SCV lever that corresponds with the steering hydraulic cylinder in the 'continuous' position and manually control the steering of the wheels through the Trimble guidance monitor.

**PREPARATION AND SET UP
(CONTINUED)**

CALIBRATION (CONT.)

2. Center the stroke of the steering hydraulic cylinder.
 - A. Fully extend the steering hydraulic cylinder out and keep in place.
 - B. Place the provided calibration cylinder stop onto the rod of the steering hydraulic cylinder as shown below.
 - C. Retract the steering hydraulic cylinder until it stops against the calibration cylinder stop. Now the cylinder is in the center of its stroke.
 - D. Remove the calibration cylinder stop and place in storage.

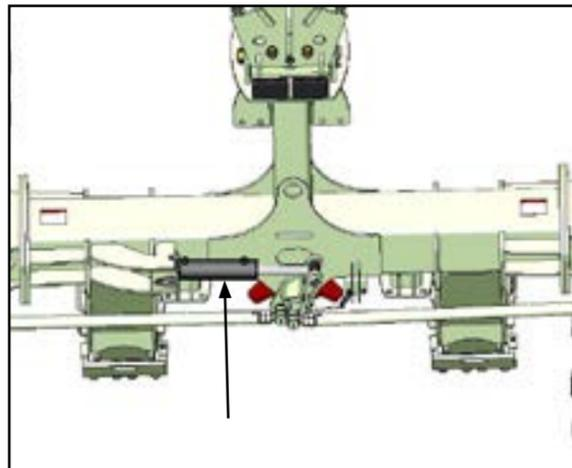

FULLY EXTEND CYLINDER

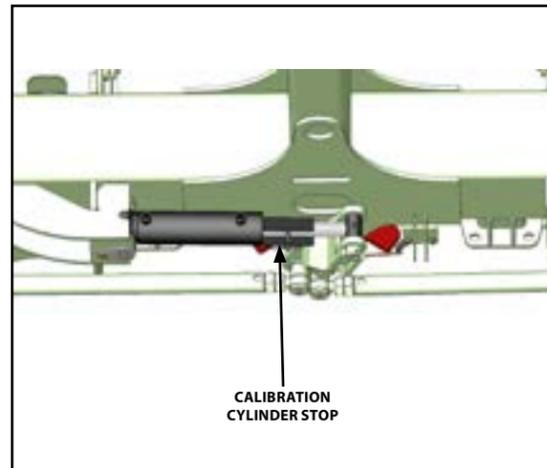

PLACE CALIBRATION CYLINDER STOP ON CYLINDER ROD

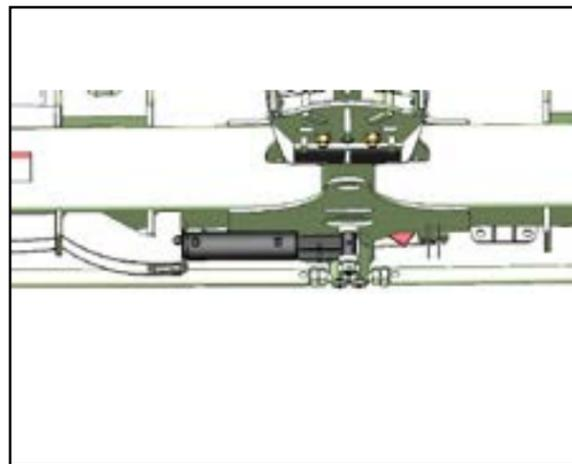

RETRACT CYLINDER AGAINST CYLINDER STOP

**PREPARATION AND SET UP
(CONTINUED)**

CALIBRATION (CONT.)

3. Center the wheels by adjusting the steering linkage struts.
 - A. Using a "square" device, measure the angle between the steering knuckle and the wheel spindle mount. This angle should be 90 degrees.
 - B. If the wheels need to be adjusted, loosen the jam nut on each end of the corresponding strut and rotate the center strut center section until 90 degrees is obtained. Retighten jam nuts.

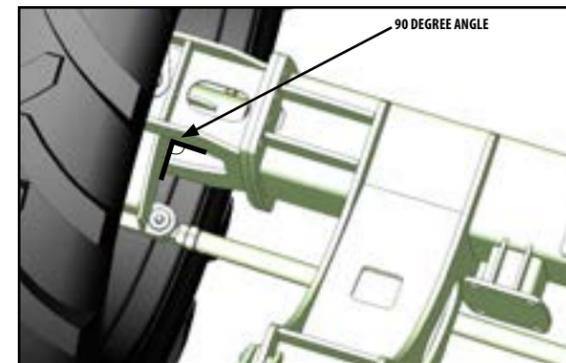

RH WHEEL ALIGNMENT MEASUREMENT

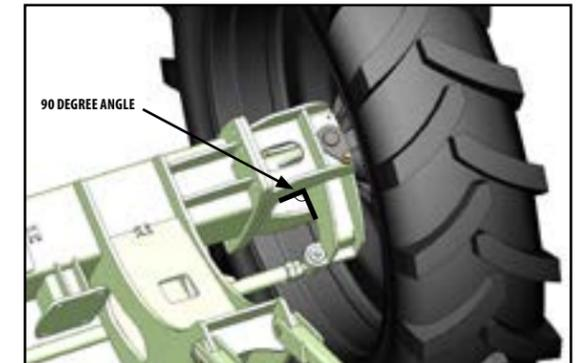

LH WHEEL ALIGNMENT MEASUREMENT

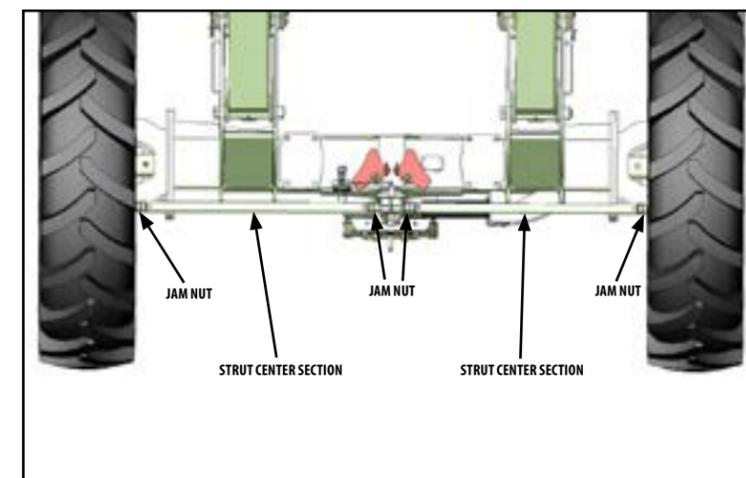

ADJUSTING WHEEL ALIGNMENT

**PREPARATION AND SET UP
(CONTINUED)**

CALIBRATION (CONT.)



4. Position the implement feedback sensor.
 - A. Once the previous calibration steps have been performed correctly (i.e. all steering components are centered), the voltage read-out found on your steering system's monitor should read close to 2.5 volts. If this is not the case, the implement feedback sensor will need to be adjusted until the read-out on the steering system's monitor reads as close as possible to 2.5 volts.
 - B. Adjust the implement feedback sensor by adjusting the sensor connecting linkage in the same manner as an adjustable strut would be adjusted.
 - C. For additional information on the implement feedback sensor, refer to your guidance system's operator's manual.

**HYDRAULICS
HOSE ROUTING**

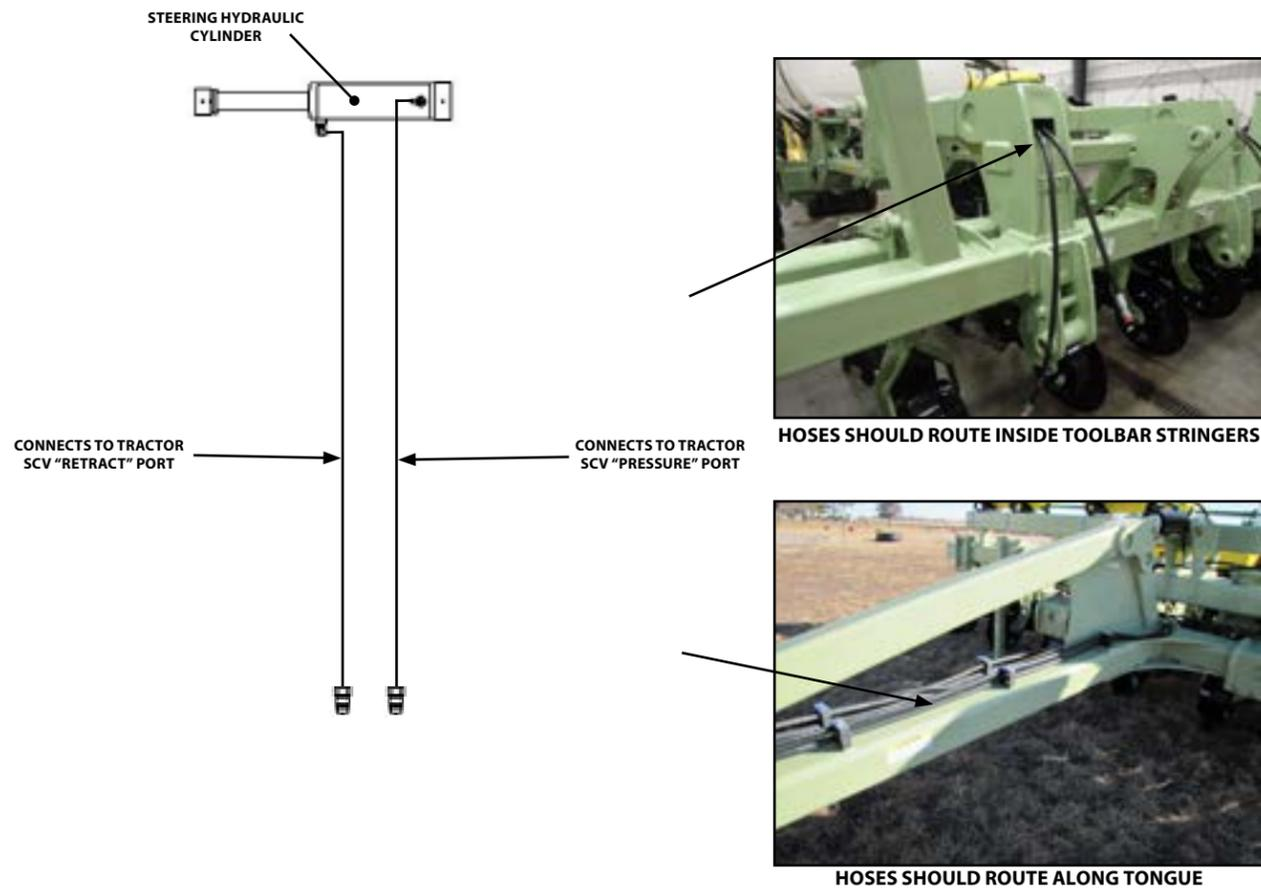

FIELD OPERATION



PLACE MACHINE TOOLBAR COMPONENTS IN "FIELD READY" POSITION:

AVOID CRUSHING. Do not stand between tractor and implement when connecting or disconnecting implement. Injury or death can result from being trapped between the tractor and implement.



AVOID CRUSHING. Be sure the weight of the machine is fully supported by the tractor and carrier lift hydraulic cylinders before removing bar stands from the storage position.



PLACE TRACTOR IN PARK AND REMOVE KEY BEFORE DISMOUNTING TRACTOR TO ADJUST IMPLEMENT.

NEVER ALLOW RIDERS ON TRACTOR OR IMPLEMENT. Riders hinder operator visibility and can be thrown from the implement and/or be struck by foreign objects resulting in injury or death.

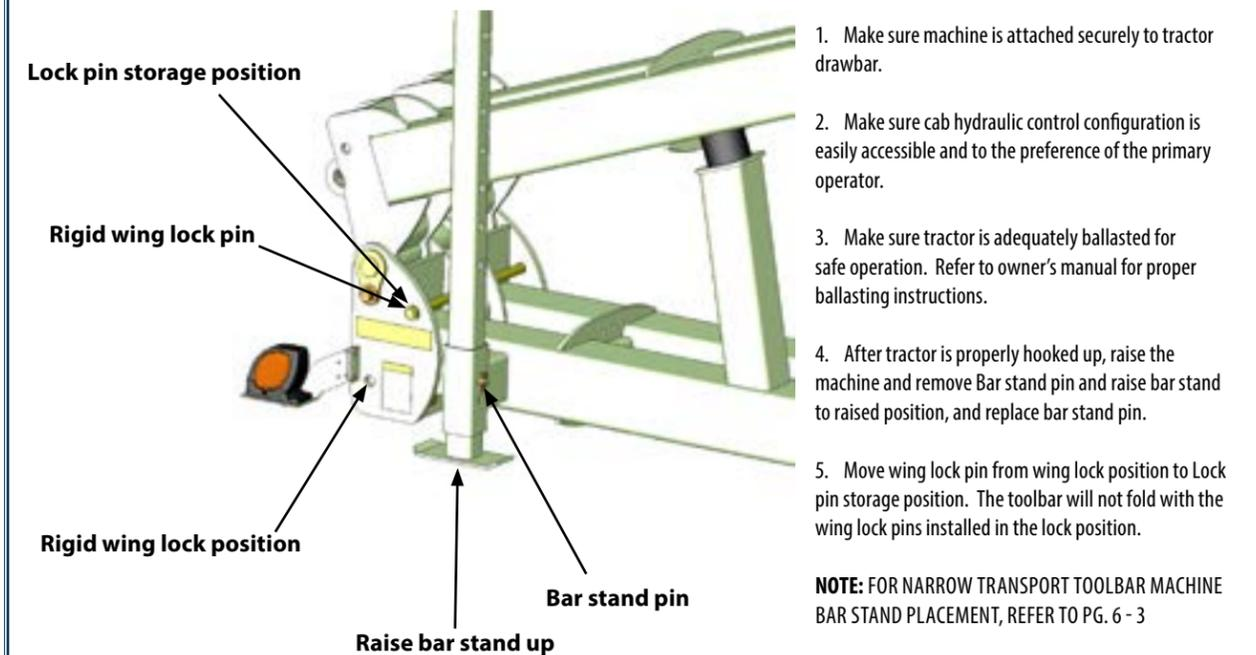

**FIELD OPERATION
(CONTINUED)**

RIGID OPERATION. For Rigid operation in the field: With wings completely unfolded, move Rigid wing lock pin from Lock pin storage position and install into Rigid wing lock position. This will keep wing from floating up. **NOTE:** TOOLBAR WILL NOT BE ABLE TO FOLD WITH WINGS LOCKED DOWN.

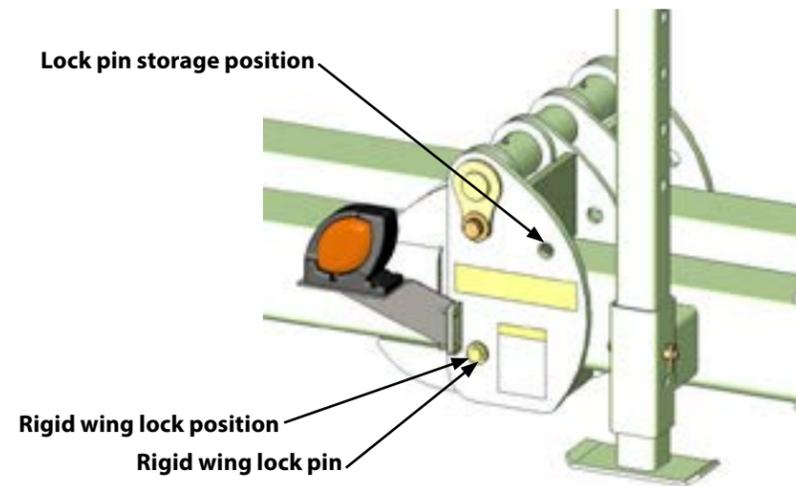

WING LEVELING. Factory setting for wing level bolts allows no downward wing position from level. If wings become out of adjustment, these bolts can be moved. Wing leveling bolts can also be adjusted so that wings will float down below factory setting. Smaller 1tRIPr[®] XD configurations will have 1 wing level bolt on each wing. Larger 1tRIPr[®] XD configurations will have 2 wing level bolts for each wing (shown below). If there are two wing level bolts per wing it is important that these bolts are adjusted so that both of them make contact with the wing so the load is distributed evenly.

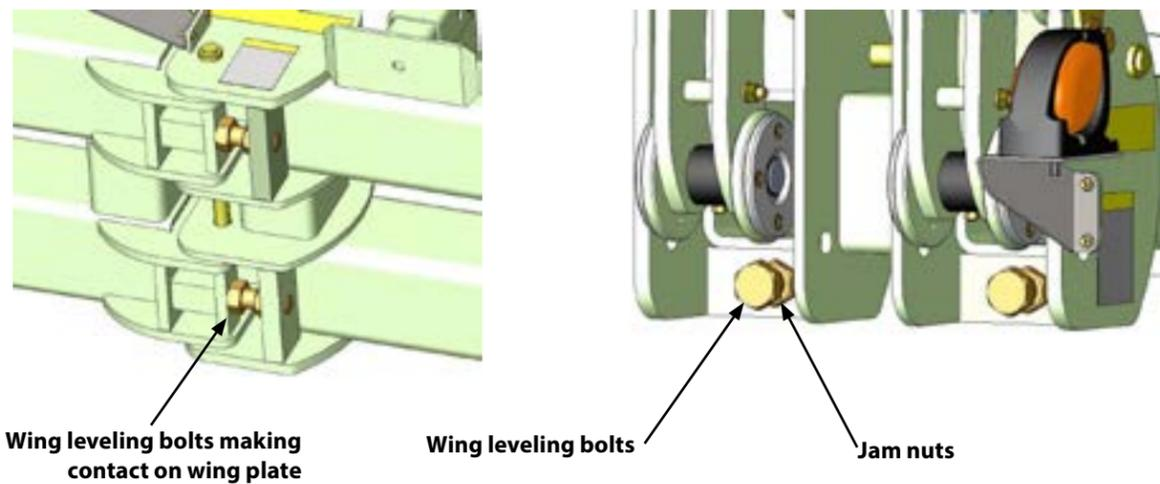

To adjust Wing leveling bolts: 1. Loosen Jam nut. 2. Adjust bolt or bolts. 3. Tighten Jam nut. Recommended Tools: 1 13/16 end wrench.

NOTE: JAM NUTS ARE IMPORTANT FOR PROTECTING THE THREADS IN THE TAPPED PLATE AND SHOULD NOT EVER BE REMOVED FROM THE ASSEMBLY.

NARROW TRANSPORT TOOLBAR STANDS



AVOID CRUSHING. Be sure the weight of the machine is fully supported by the tractor and carrier lift hydraulic cylinders before removing bar stands from the storage position.

“FIELD-READY” BAR STAND PLACEMENT. Narrow Transport 1tRIPr[®] XD machines are equipped with bar stands that differ from the bar stands of standard toolbar machines. In order for proper machine folding, these bar stands must be rotated inward as shown, rather than raised up as they do on standard toolbar machines.

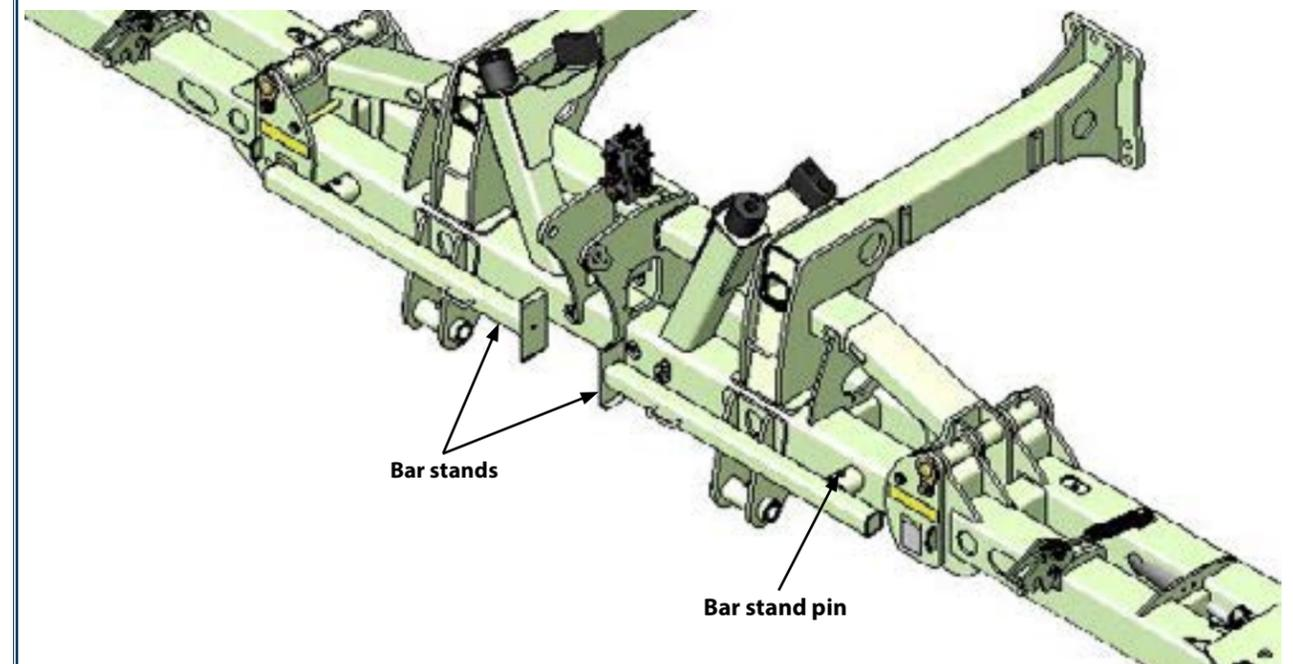

TOOLBAR HEIGHT AND ORIENTATION



⚠️ PLACE TRACTOR IN PARK AND REMOVE KEY BEFORE DISMOUNTING TRACTOR TO ADJUST IMPLEMENT.



NEVER ALLOW RIDERS ON TRACTOR OR IMPLEMENT. Riders hinder operator visibility and can be thrown from the implement and/or be struck by foreign objects resulting in injury or death.

NOTE: WHEN SETTING TOOLBAR HEIGHT AND ORIENTATION, DISREGARD ROW UNIT PERFORMANCE. TOOLBAR HEIGHT AND ORIENTATION MUST BE ESTABLISHED PRIOR TO TOOLING ADJUSTMENT. FOR 1TRIPR® TOOLING ADJUSTMENT, REFER TO THE 1TRIPR® ROW UNIT OPERATOR'S MANUAL.

The top and bottom of the toolbar must operate parallel with the ground surface. Adjustment of tractor hitch tab height, tongue lift cylinder stops, and/or lifting gauge wheel cylinder stops, will allow the toolbar to operate parallel with the ground surface.

Have an assistant pull the tractor and implement slowly forward in the field position as you view the end of the toolbars from a safe distance. Observe the toolbars heights and orientations while in operation. Make adjustments accordingly until the top and bottom of both toolbars operate parallel with the ground surface.

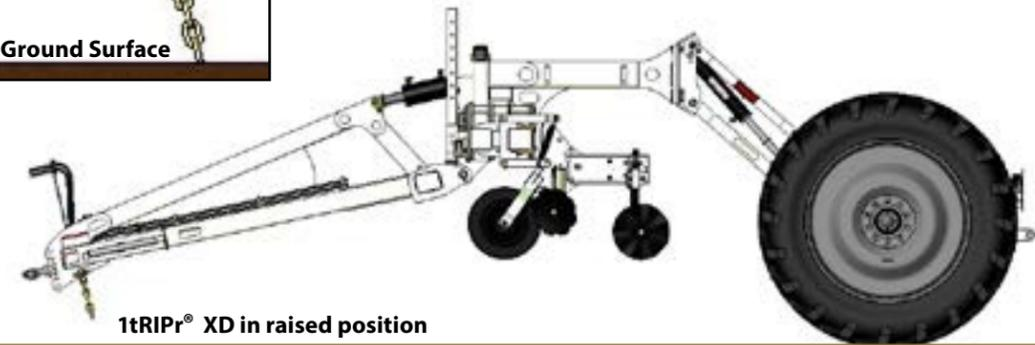
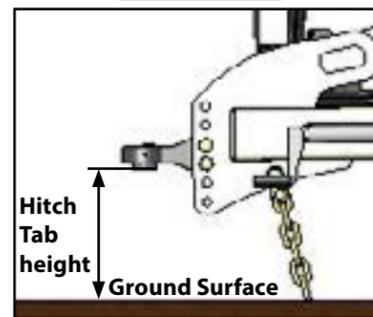

1tRIPr® XD in raised position

In the raised position, there should be adequate clearance between the ground surface and the 1tRIPr® shank.

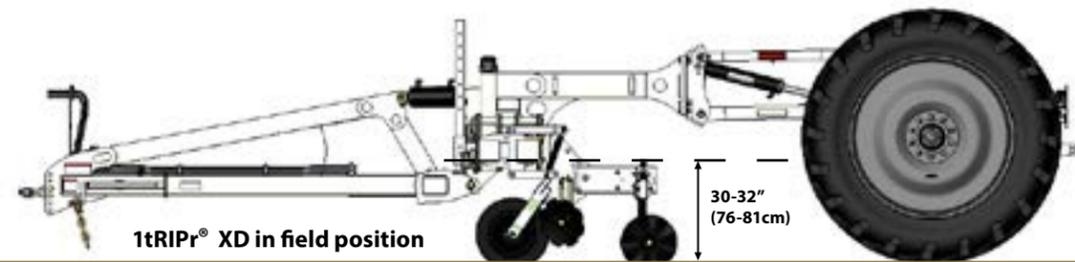

1tRIPr® XD in field position

1. In the field position, the 1tRIPr® XD toolbar should run 30"-32" (76-81 cm) above the ground surface.
2. Row unit parallel linkage should run parallel with the ground surface and not be resting on the toolbar.

NT TOOLBAR FOLDING PROCESS



⚠️ AVOID CRUSHING. Make sure all personnel are clear of implement at all times implement is in motion. Be aware of obstructions above, below, and around implement when in operation or transport. Injury or death can result from being struck by the implement.

The 1tRIPr® XDNT machine uniquely folds into a more compact configuration for easier transport. During the folding process, two different folding actions will occur. First, from the unfolded state, the outer wings will revolve inward towards the tractor, until they become seated and "locked" in the outer wing latch (A, B, and C). Next, the mid wings will begin to fold vertically until they make contact with the wing rests on the toolbar center section (D and E). The machine is now folded and ready for transport.

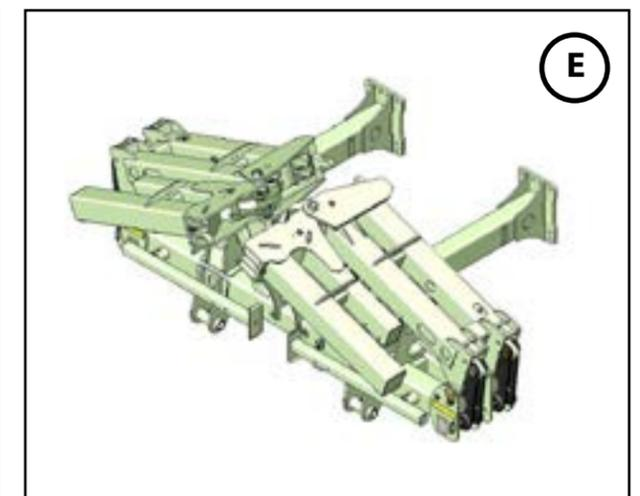
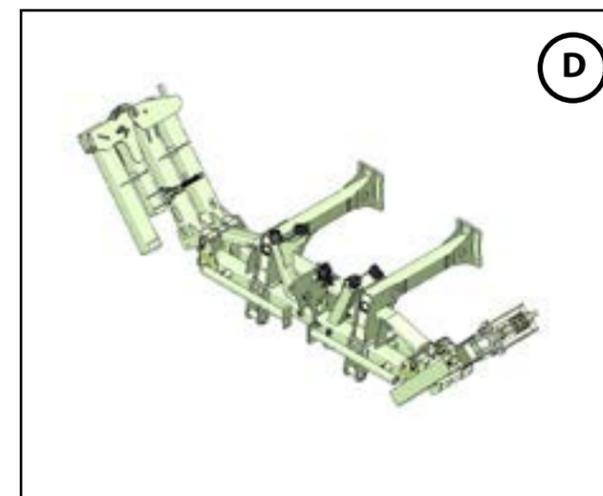
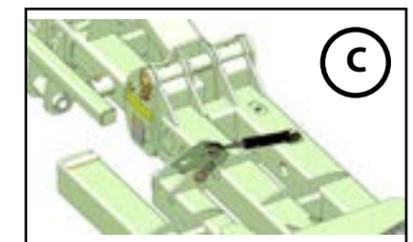
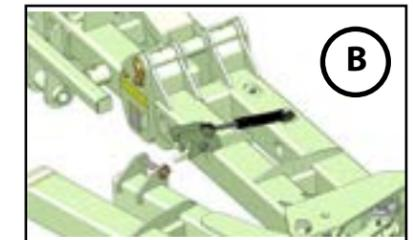
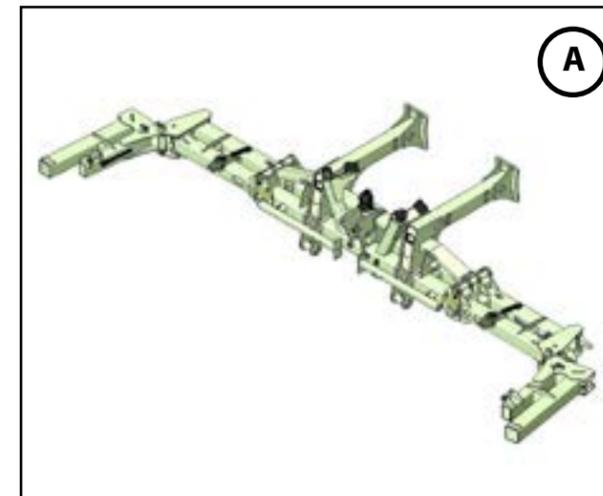

NT MANIFOLD BLOCK IDENTIFICATION

The 1tRIPr[®] XDNT is equipped with a hydraulic manifold block and a gear flow divider located near the top link center mast plates, which directs oil to multiple cylinders that must perform together to accomplish a specific function. Below is a port identification chart of the hydraulic manifold block of the 1tRIPr[®] XDNT.

NOTE: For specific hydraulic hose specifications, refer to "Narrow Transport Machine Hydraulic Hoses" in the parts section of this manual.

HYDRAULIC MANIFOLD BLOCK #180-310		
PORT	HOSE ASSIGNMENT	FUNCTION
FOLD	TRACTOR TO MANIFOLD PRESSURE I	SUPPLIES OIL TO MANIFOLD TO EXTEND WING FOLD CYLINDERS
UNFOLD	TRACTOR TO MANIFOLD RETRACT I	SUPPLIES OIL TO MANIFOLD TO RETRACT WING FOLD CYLINDERS
LAWP	TRACTOR TO MANIFOLD PRESSURE II	SUPPLIES OIL TO MANIFOLD TO LIFT MACHINE
LAWR	TRACTOR TO MANIFOLD RETRACT II	SUPPLIES OIL TO MANIFOLD TO LOWER MACHINE
OWP*	MANIFOLD TO LEFT OUTER WING FOLD AND LATCH CYLINDER TEE FITTING 1	SUPPLIES OIL TO LEFT OUTER WING FOLD CYLINDER AND LATCH CYLINDER DURING FOLDING
OWR*	MANIFOLD TO LEFT OUTER WING FOLD AND LATCH CYLINDER TEE FITTING 2	SUPPLIES OIL TO LEFT OUTER WING FOLD CYLINDER AND LATCH CYLINDER DURING UNFOLDING
LAWP*	MANIFOLD TO LIFT CYLINDER (BASE END)	SUPPLIES OIL TO LIFT CYLINDER 1 DURING MACHINE LIFTING
LAWR*	FITTED WITH TEE 1. MANIFOLD TO LIFT CYLINDER (ROD END) 2. MANIFOLD TO TONGUE CYLINDER (ROD END)	SUPPLIES OIL TO LIFT CYLINDER 1 AND TONGUE CYLINDER DURING MACHINE LOWERING
OWP**	MANIFOLD TO RIGHT OUTER WING FOLD AND LATCH CYLINDER TEE FITTING 1	SUPPLIES OIL TO RIGHT OUTER WING FOLD CYLINDER AND LATCH CYLINDER DURING FOLDING
OWR**	MANIFOLD TO RIGHT OUTER WING FOLD AND LATCH CYLINDER TEE FITTING 2	SUPPLIES OIL TO RIGHT OUTER WING FOLD CYLINDER AND LATCH CYLINDER DURING UNFOLDING
LAWP**	MANIFOLD TO LIFT CYLINDER (BASE END)	SUPPLIES OIL TO LIFT CYLINDER 2 DURING MACHINE LIFTING
LAWR**	MANIFOLD TO LIFT CYLINDER (ROD END)	SUPPLIES OIL TO LIFT CYLINDER 2 DURING MACHINE LOWERING
GW*	MANIFOLD TO TONGUE CYLINDER (BASE END)	SUPPLIES OIL TO TONGUE CYLINDER DURING MACHINE LIFTING
R3**	MANIFOLD TO FOLD CYLINDER RETRACT TEE FITTING 1	SUPPLIES OIL TO RIGHT MID WING FOLD CYLINDERS DURING UNFOLDING
R4*	MANIFOLD TO FOLD CYLINDER RETRACT TEE FITTING 2	SUPPLIES OIL TO LEFT MID WING FOLD CYLINDERS DURING UNFOLDING
ST DIV*	MANIFOLD TO GEAR FLOW DIVIDER	SUPPLIES OIL TO MID WING FOLD CYLINDERS DURING FOLDING
P1**, P2*, and GW**	PORTS NOT USED	PORTS SHOULD BE PLUGGED

* - Ports located on the left side of the hydraulic manifold block when viewing from the rear of the machine.

** - Ports located on the right side of the hydraulic manifold block when viewing from the rear of the machine.

STANDARD MACHINE FOLD HYDRAULIC HOSE ROUTING

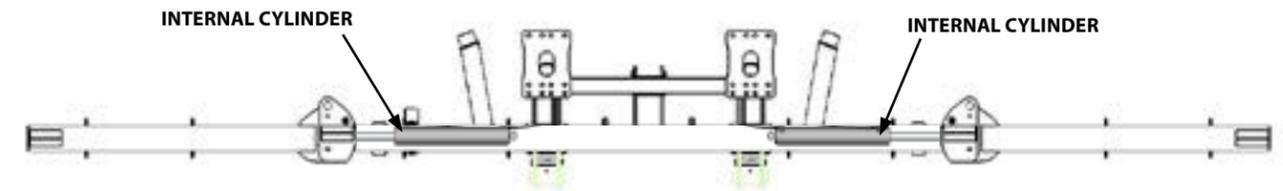

2 CYLINDER FOLDING TOOLBARS (12R30 AND SMALLER CONFIGURATIONS)



For individual hose identification, refer to the Hydraulic Manifold Block Port Identification and Toolbar Hydraulic Hose parts identification.

4 CYLINDER FOLDING TOOLBARS (12R36 AND LARGER CONFIGURATIONS)

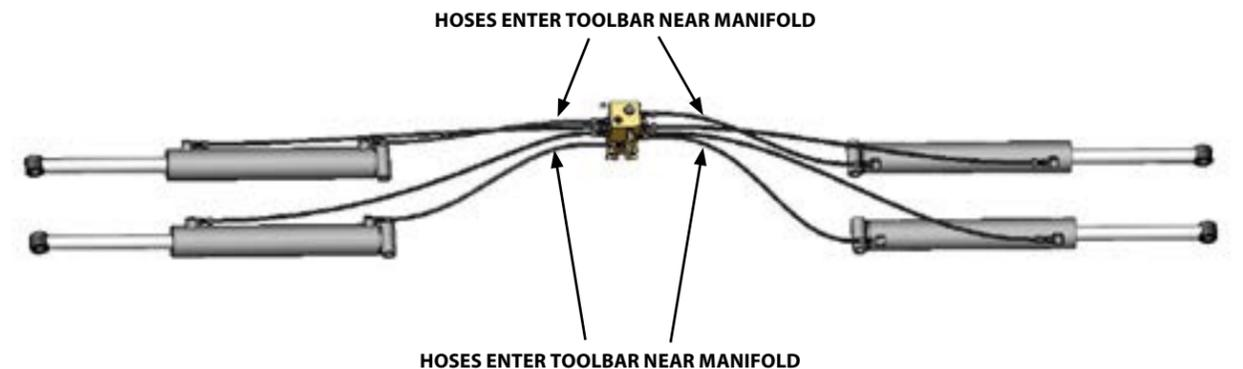

For individual hose identification, refer to the Hydraulic Manifold Block Port Identification and Toolbar Hydraulic Hose parts identification.

**MACHINE LIFT HYDRAULIC HOSE ROUTING
(STANDARD AND NT)**

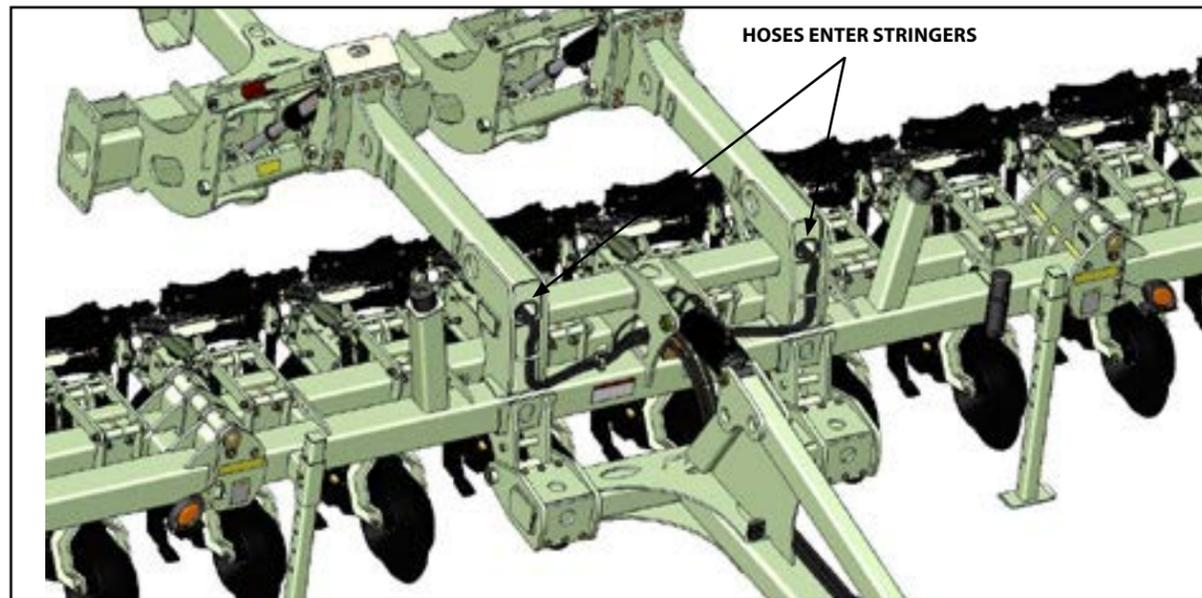
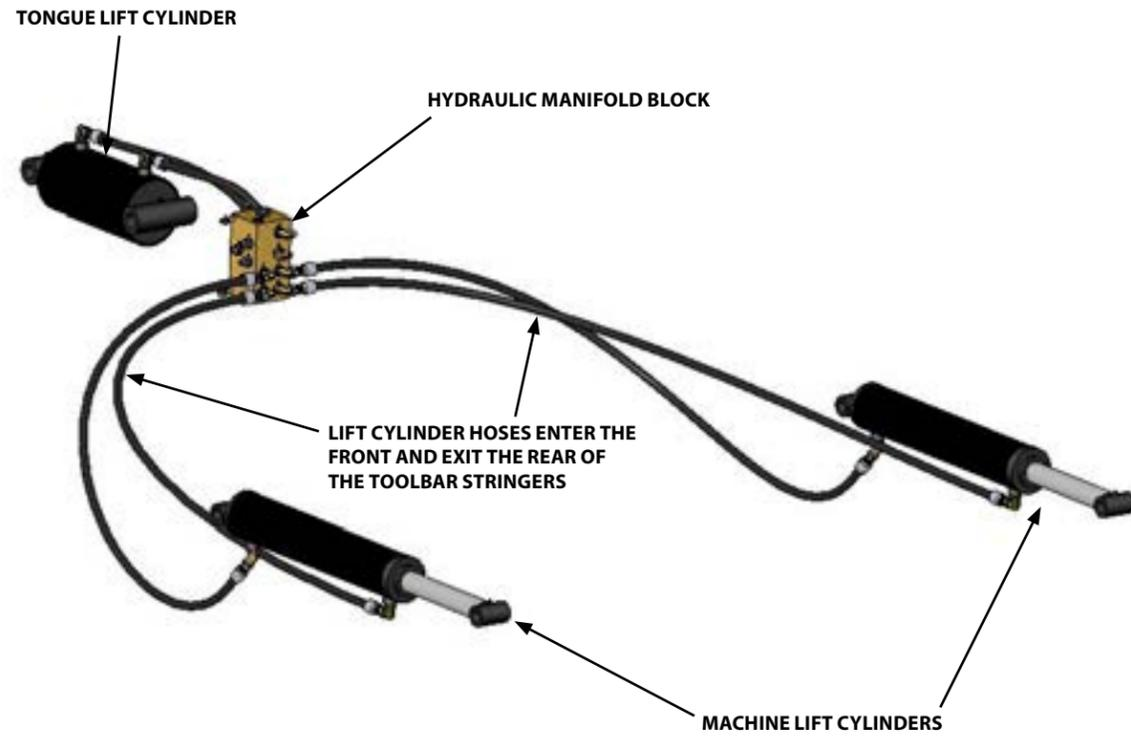

For individual hose identification, refer to the Hydraulic Manifold Block Port Identification and Toolbar Hydraulic Hose parts identification.

**NARROW TRANSPORT MACHINE FOLD
HYDRAULIC HOSE ROUTING**

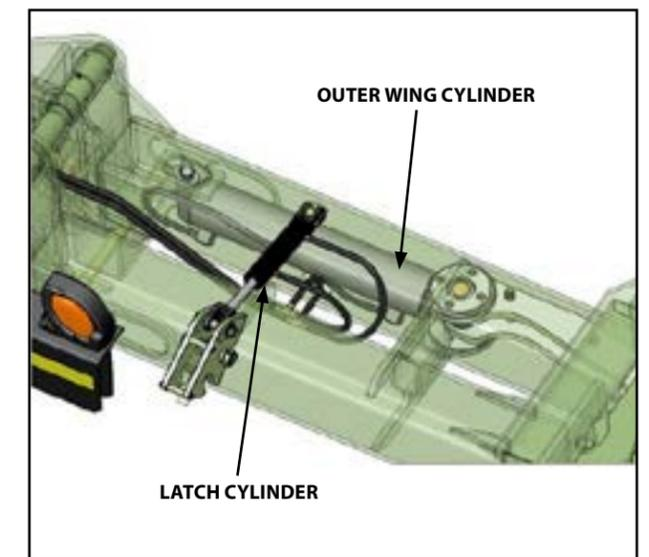
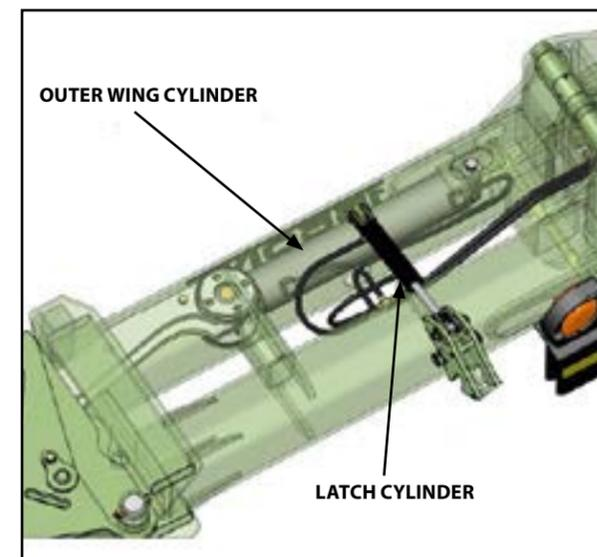
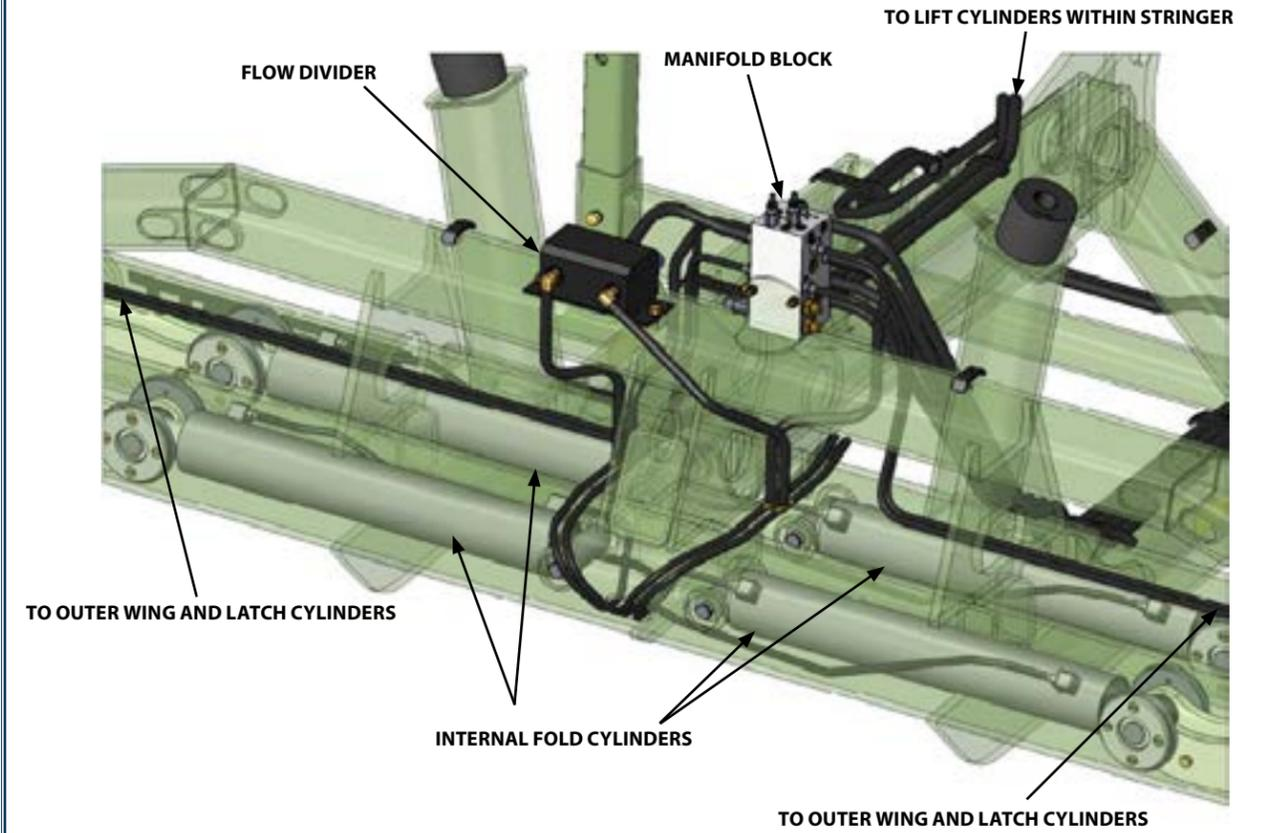

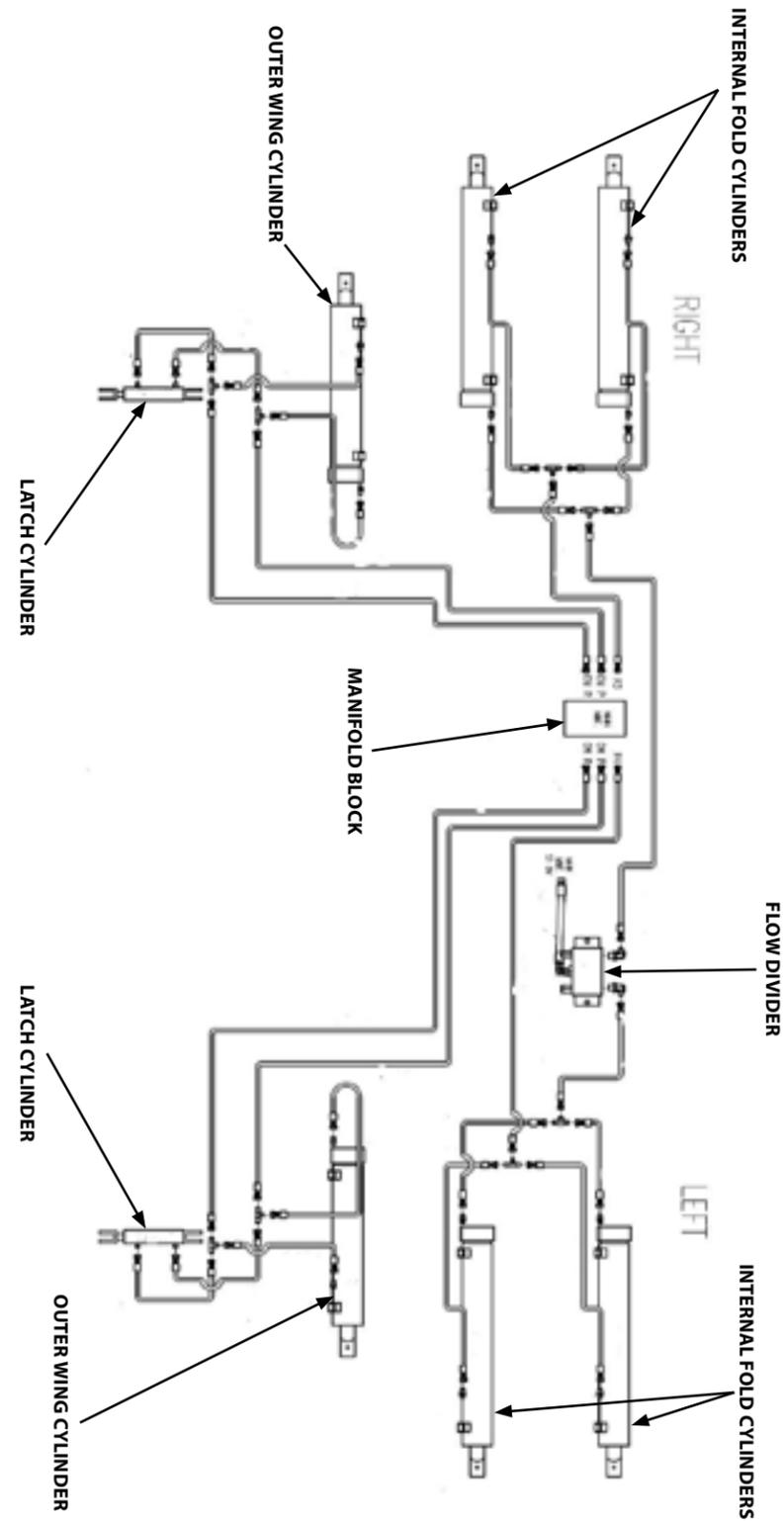

NOTE: For specific hydraulic hose specifications, refer to "Narrow Transport Machine Hydraulic Hoses" in the parts section of this manual.

**NARROW TRANSPORT MACHINE FOLD
HYDRAULIC HOSE SCHEMATIC**



AVOID CRUSHING. Make sure all personnel are clear of the implement. Lower implement to the ground, place tractor in park, turn off engine, and remove key.

USE BAR STANDS TO SUPPORT THE IMPLEMENT. Park implement on a clean, dry, and level surface. An uneven surface could cause implement to shift or fall, resulting in injury or death, as well as implement damage. Securely support all implement components that must be raised. Remove buildup of grease, oil, or debris prior to adjusting implement.

PROBLEM:
Wings do not fold or unfold.

SOLUTION OPTIONS:

1. Rigid wing lock pins installed.
 - Remove wing lock pins.
2. Hydraulic tips installed incorrectly in tractor SCV.
 - Refer to tractor operator's manual or dealer for tractor hydraulic specifications.
3. Tractor hydraulic pressure is insufficient.
 - Refer to tractor operator's manual or dealer for tractor hydraulic specifications.



NOTE: TO AVOID FOREIGN OBJECTS IN HYDRAULIC OIL, ALWAYS CLEAN HYDRAULIC TIPS AND OUTLETS. FOREIGN MATERIAL CAN RUIN CYLINDERS AND PLUG RESTRICTORS.



⚠ AVOID CRUSHING. Make sure all personnel are clear of the implement. Lower implement to the ground, place tractor in park, turn off engine, and remove key.

USE BAR STANDS TO SUPPORT THE IMPLEMENT. Park implement on a clean, dry, and level surface. An uneven surface could cause implement to shift or fall, resulting in injury or death, as well as implement damage. Securely support all implement components that must be raised. Remove buildup of grease, oil, or debris prior to adjusting implement.

PROBLEM:

Wings do not fold or unfold. (cont.)

SOLUTION OPTIONS:

4. Hydraulic manifold block/flow divider is faulty or plugged.
 - Refer to (pg. 10 - 21) for hydraulic manifold breakdown.
 - Manifold block/flow divider may need to be removed and cleaned or possibly replaced.
5. Hydraulic cylinder restrictors could be plugged.
 - Refer to (pg. 8 - 3) for removal process of cylinder assembly.
 1. Remove hose from cylinder.
 2. Remove adaptor that goes in-between hose and cylinder port.
 3. Restrictor is located inside the adaptor and can be removed with allen wrench.
 4. Restrictor is made from a set screw with a .055 hole drilled in it.
 5. Check to see if hole is plugged.
 6. Clean and re-install.
6. Cylinder seal kit is bad.
 - Replace cylinder seal kit.

NOTE: TO AVOID FOREIGN OBJECTS IN HYDRAULIC OIL, ALWAYS CLEAN HYDRAULIC TIPS AND OUTLETS. FOREIGN MATERIAL CAN RUIN CYLINDERS AND PLUG RESTRICTORS.



⚠ AVOID CRUSHING. Make sure all personnel are clear of the implement. Lower implement to the ground, place tractor in park, turn off engine, and remove key.

USE BAR STANDS TO SUPPORT THE IMPLEMENT. Park implement on a clean, dry, and level surface. An uneven surface could cause implement to shift or fall, resulting in injury or death, as well as implement damage. Securely support all implement components that must be raised. Remove buildup of grease, oil, or debris prior to adjusting implement.

REMOVAL OF INTERNAL CYLINDER

FOLD TOOLBAR:

1. Be sure rigid locking pin is in storage position.
2. Fold wings over until they hit wing stops so weight of wings are on stops.

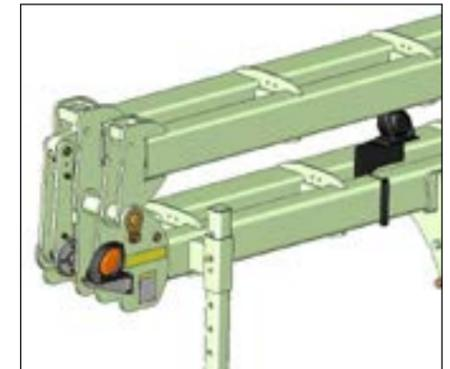

DISCONNECT HYDRAULIC HOSES:

1. Relieve hydraulic system pressure in tractor.
2. Unhook hydraulic hoses and store in courtesy palette.

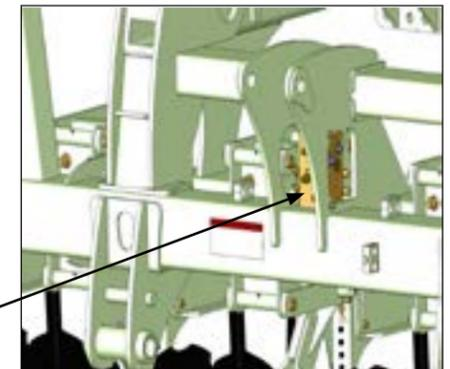

Hydraulic manifold

3. Locate cylinder hoses on the hydraulic manifold and disconnect. The wing hoses will be located on the sides of the hydraulic manifold block.

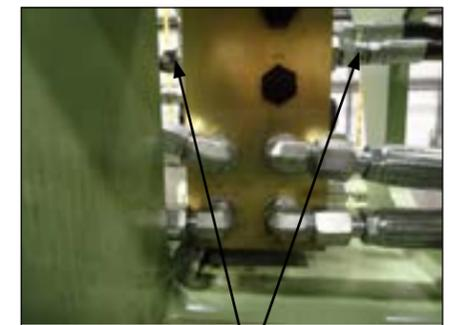

Wing hoses



AVOID CRUSHING. Make sure all personnel are clear of the implement. Lower implement to the ground, place tractor in park, turn off engine, and remove key.

USE BAR STANDS TO SUPPORT THE IMPLEMENT. Park implement on a clean, dry, and level surface. An uneven surface could cause implement to shift or fall, resulting in injury or death, as well as implement damage. Securely support all implement components that must be raised. Remove buildup of grease, oil, or debris prior to adjusting implement.

DISCONNECT STRAPS:

1. Remove bolt that holds pin in.

2. Remove pin. Weight of cylinder assembly may need to be supported to remove pin.

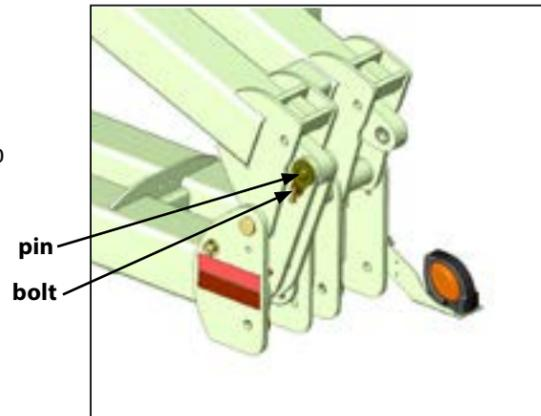

REMOVE CYLINDER PIN:



1. With snap ring pliers, remove snap ring from pin (in-between bars).

2. Remove pin from toolbar. (cylinder should be loose at this point).

(for re-assembly use alignment punch to align cylinder and pin)

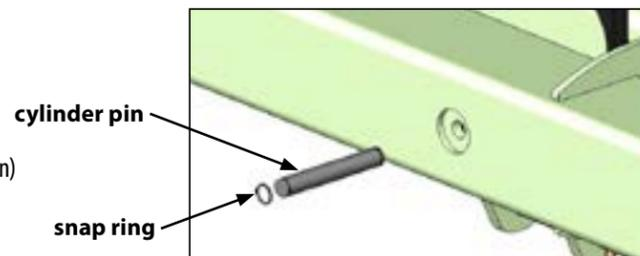

REMOVE CYLINDER:

1. Make sure hose ends are covered.

2. Tie twine or wire to hoses to aid in re-assembly.

3. Pull cylinder out of toolbar tube.

Reverse process for re-assembly.

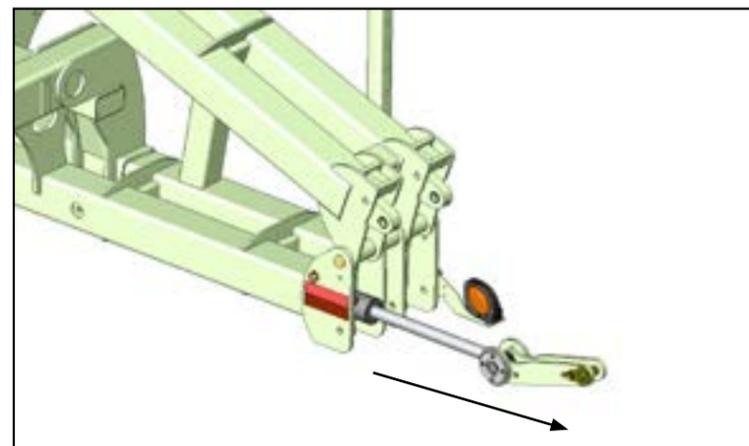

AVOID CRUSHING. Make sure all personnel are clear of the implement. Lower implement to the ground, place tractor in park, turn off engine, and remove key.

USE BAR STANDS TO SUPPORT THE IMPLEMENT. Park implement on a clean, dry, and level surface. An uneven surface could cause implement to shift or fall, resulting in injury or death, as well as implement damage. Securely support all implement components that must be raised. Remove buildup of grease, oil, or debris prior to adjusting implement.

PROBLEM:

Machine will not raise or lower

SOLUTION OPTIONS:

1. Hydraulic hoses may be connected to the wrong hydraulic remotes on tractor.

- It is important that hydraulic hoses are connected to the correct hydraulic remotes (pressure or retract) on the tractor.
- Locate the machine lift hoses on the tongue of the machine. (Refer to pg 3-10 for identification information.)
- Locate the “extend” and “retract” symbols on the green handles of the lift hydraulic hoses.
- “Extend” labeled hose should be in pressure tractor hydraulic remote and “Retract” labeled hose should be in retract tractor hydraulic remote.

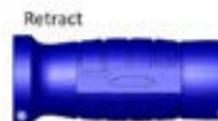

HOSE SYMBOL IDENTIFICATION

2. Machine safety transport lock may be installed.

- The “red” safety transport lock, which installs on the lift cylinder rod, prevents the machine from lowering during transport.
- Remove safety transport lock and place in storage position.

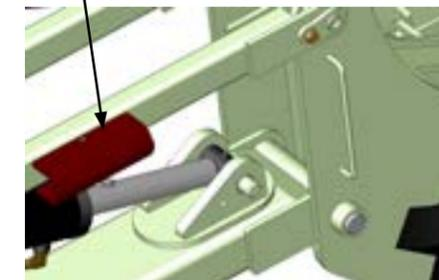

REAR OF CARRIER ARMS

TORQUE SPECIFICATIONS

Unified Inch Bolt and Screw Torque Values

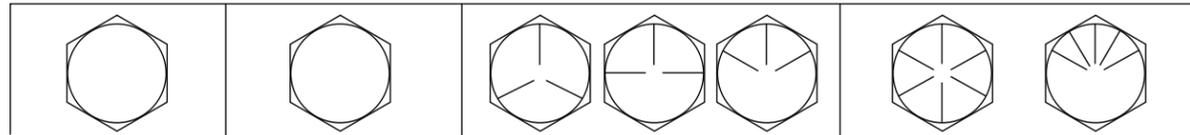

Bolt or Screw Size	SAE Grade 1				SAE Grade 2 ^a				SAE Grade 5, 5.1 or 5.2				SAE Grade 8 or 8.2			
	Lubricated ^b		Dry ^c		Lubricated ^b		Dry ^c		Lubricated ^b		Dry ^c		Lubricated ^b		Dry ^c	
	N·m	lb-in	N·m	lb-in	N·m	lb-in	N·m	lb-in	N·m	lb-in	N·m	lb-in	N·m	lb-in	N·m	lb-in
1/4	3.7	33	4.7	42	6	53	7.5	66	9.5	84	12	106	13.5	120	17	150
													N·m	lb-ft	N·m	lb-ft
5/16	7.7	68	9.8	86	12	106	15.5	137	19.5	172	25	221	28	20.5	35	26
									N·m	lb-ft	N·m	lb-ft				
3/8	13.5	120	17.5	155	22	194	27	240	35	26	44	32.5	49	36	63	46
			N·m	lb-ft	N·m	lb-ft	N·m	lb-ft								
7/16	22	194	28	20.5	35	26	44	32.5	56	41	70	52	80	59	100	74
	N·m	lb-ft														
1/2	34	25	42	31	53	39	67	49	85	63	110	80	120	88	155	115
9/16	48	35.5	60	45	76	56	95	70	125	92	155	115	175	130	220	165
5/8	67	49	85	63	105	77	135	100	170	125	215	160	240	175	308	225
3/4	120	88	150	110	190	140	240	175	300	220	380	280	425	315	540	400
7/8	190	140	240	175	190	140	240	175	490	360	615	455	690	510	870	640
1	285	210	360	265	285	210	360	265	730	540	920	680	1030	760	1300	960
1-1/8	400	300	510	375	400	300	510	375	910	670	1150	850	1450	1075	1850	1350
1-1/4	570	420	725	535	570	420	725	535	1280	945	1630	1200	2050	1500	2600	1920
1-3/8	750	550	950	700	750	550	950	700	1700	1250	2140	1580	2700	2000	3400	2500
1-1/2	990	730	1250	930	990	730	1250	930	2250	1650	2850	2100	3600	2650	4550	3350

Torque values listed are for general use only, based on the strength of the bolt or screw. DO NOT use these values if a different torque value or tightening procedure is given for a specific application. For plastic insert or crimped steel type lock nuts, for stainless steel fasteners, or for nuts on U-bolts, see the tightening instructions for the specific application. Shear bolts are designed to fail under predetermined loads. Always replace shear bolts with identical grade.

Replace fasteners with the same or higher grade. If higher grade fasteners are used, tighten these to the strength of the original. Make sure fastener threads are clean and that you properly start thread engagement. When possible, lubricate plain or zinc plated fasteners other than lock nuts, wheel bolts or wheel nuts, unless different instructions are given for the specific application.

^aGrade 2 applies for hex cap screws (not hex bolts) up to 6 in. (152 mm) long. Grade 1 applies for hex cap screws over 6 in. (152 mm) long, and for all other types of bolts and screws of any length.

^b"Lubricated" means coated with a lubricant such as engine oil, fasteners with phosphate and oil coatings, or 7/8 in. and larger fasteners with JDM F13C zinc flake coating.

^c"Dry" means plain or zinc plated without any lubrication, or 1/4 to 3/4 in. fasteners with JDM F13B zinc flake coating.

DMSZ

LUBRICATION

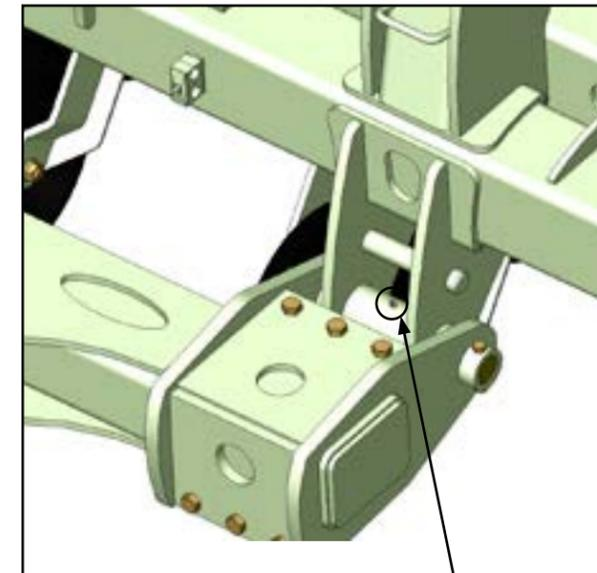
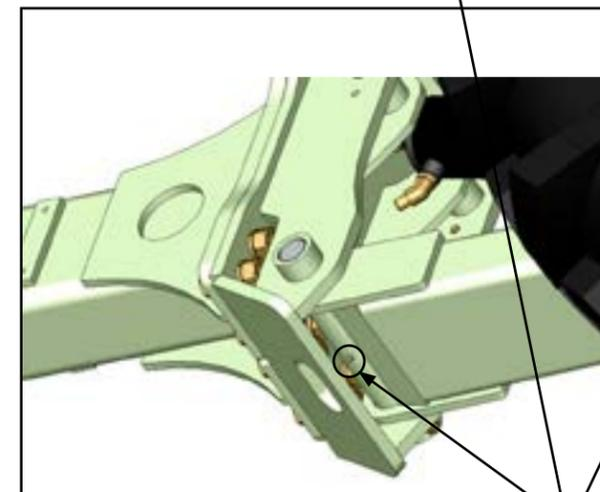
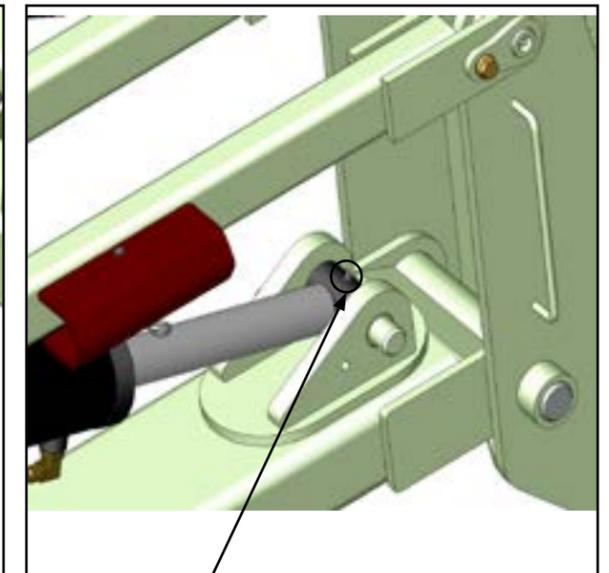
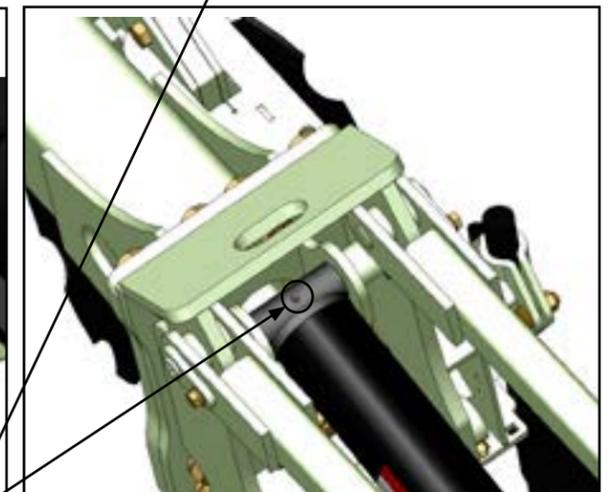

- Grease - use high quality multi-purpose grease.
- Follow recommended 50 hour service interval illustrated below.

TONGUE HITCH MODULE

REAR OF CARRIER ARM

FRONT BOTTOM OF CARRIER ARM

FRONT TOP OF CARRIER ARM

LUBRICATION

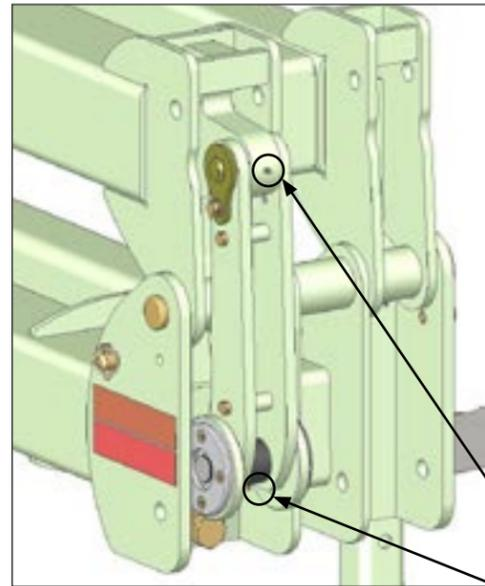

- Grease - use high quality multi-purpose grease.
- Follow recommended hourly service interval illustrated below.

SINGLE CYLINDER TOOLBARS



DUAL CYLINDER TOOLBAR

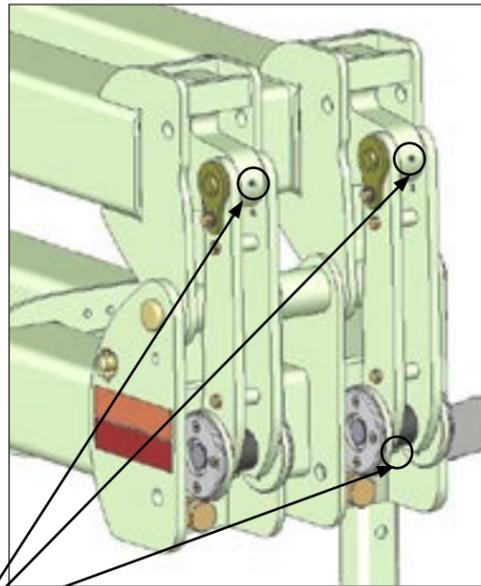

Tongue Lift Cylinder pins

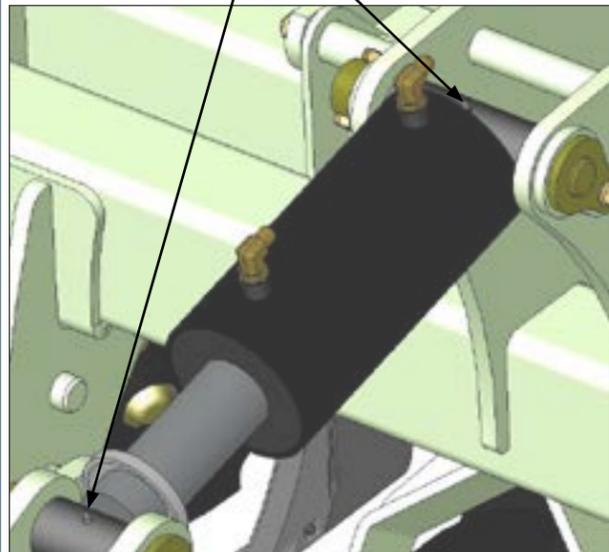

Internal fold

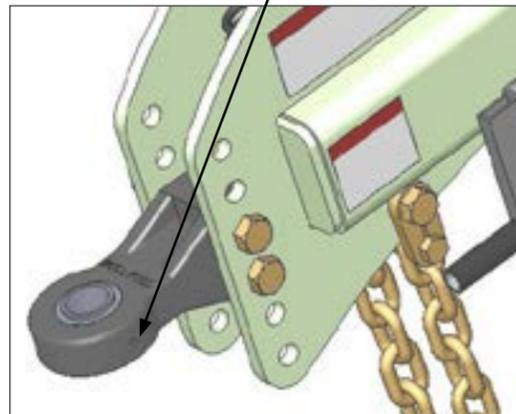

Tongue Hitch Tab

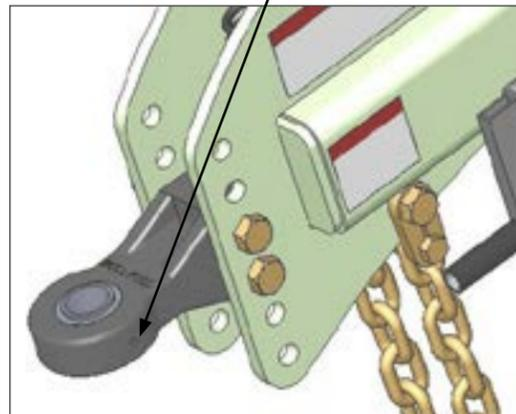

LUBRICATION



- Grease - use high quality multi-purpose grease.
- Follow recommended hourly service interval illustrated below.

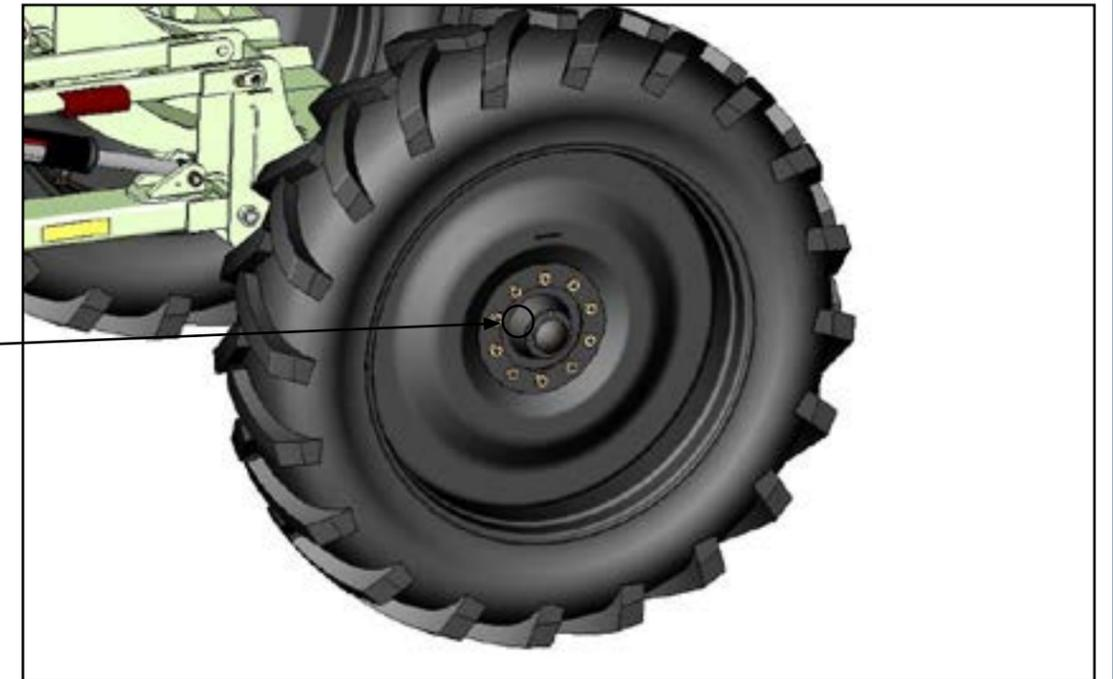

Wheel bearing

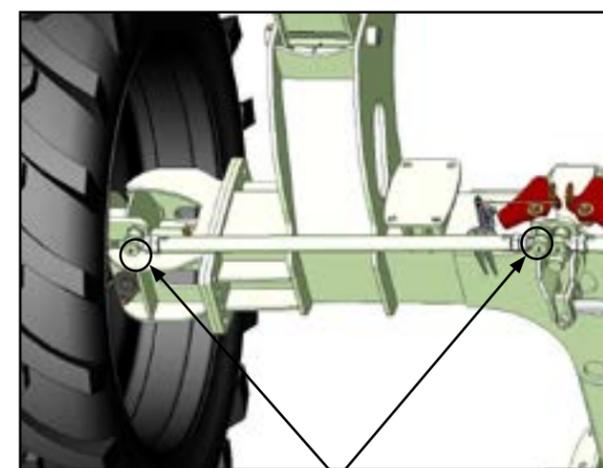

Steering strut

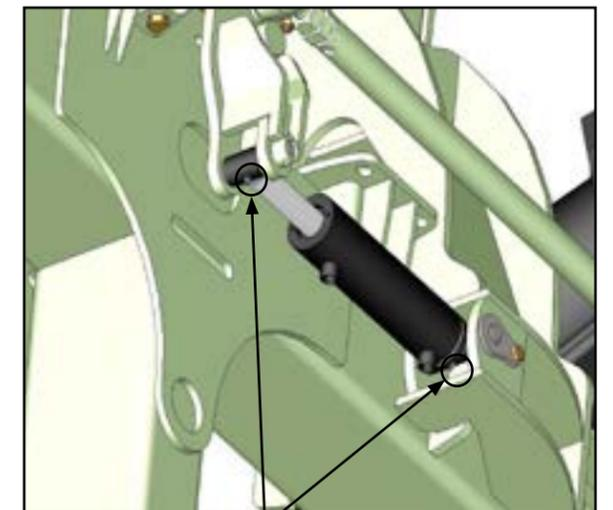

Steering hydraulic cylinder



LUBRICATION

- Grease - use high quality multi-purpose grease.
- Follow recommended 50 hour service interval illustrated below.

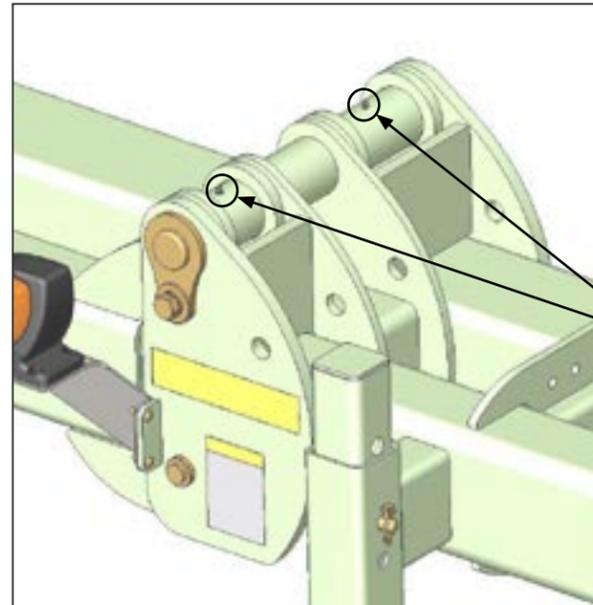

50
Wing Hinge bushings
2 zerks on each wing

IMPLEMENT INSPECTION



- When replacement parts are necessary for periodic maintenance and servicing, genuine factory replacement parts must be used to restore implement to original specifications. Replace broken or worn parts immediately. Contact your Orthman dealer for replacement parts.
- During break-in (40 hours), check hardware for proper torque every 10 to 20 hours.
- Before each use, check hardware for wear and proper torque. Replace damaged or missing hardware with hardware of an identical grade to restore implement to original specifications.
- Do not allow debris to buildup on any surface of the implement.
- Replace all shields and guards. Be sure all tools, parts, and service equipment are removed prior to transporting equipment.



IMPLEMENT STORAGE

- Clean and touch up paint seasonally to avoid corrosion and rust. Contact your Orthman dealer for touch up paint.
- Inspect all safety and Orthman decals and replace if missing or damaged. Contact your Orthman dealer for replacement decals.
- Grease all zerks regardless of hourly interval prior to storage.
- Check all hardware according to torque specifications prior to storage.
- Replace all worn or damaged parts prior to storage.
- Store inside if possible. Storing implement inside will prolong the life of the components.



- **AVOID CRUSHING.** Make sure all personnel are clear of the implement. Lower implement to the ground, place tractor in park, turn off engine, and remove key.

Storing implement on the ground will relieve the tractor three point hitch of hydraulic pressure. Hydraulic systems tend to settle, endangering anything underneath the implement.



USE BAR STANDS TO SUPPORT THE IMPLEMENT. Store implement on a clean, dry, and level surface. An uneven surface could cause implement to shift or fall, resulting in injury or death, as well as implement damage. Securely support all implement components that must be raised. Store implement away from human activity.

- **AVOID CRUSHING.** Never use the tongue bar stand to support the weight of the machine. Tongue bar stand may fail if machine weight rests on the tongue bar stand. Only use the tongue bar stand to keep the tongue from resting on the ground.

PARTS IDENTIFICATION

TONGUE ASSEMBLY

Key	Part #	Description	Qty	Notes	Key	Part #	Description	Qty	Notes
1	348-196	Tongue Frame	1	---	21	196-373	Hydraulic Hose	4	1/2"
2	348-184	Tongue Module	2	---	22	198-326	Union	4	3/4MJ x 3/4MJ
3	348-183	Module Clamp	2	---	23	152-299	Hose Holder	1	
4	100-156	Bolt	6	3/4" x 2", Grade 5	24	100-115	Bolt	1	1/2" x 1 1/4", Grade 5
5	100-158	Bolt	6	3/4" x 2 1/2", Grade 5	25	108-020	Lock washer	1	1/2"
6	102-105	Flange nut	12	3/4", serrated	26	108-001	Flat washer	1	1/2" SAE
7	100-124	Bolt	2	1/2" x 3 1/4", Grade 5	27	352-067	Tongue Stand	1	
8	102-028	Lock nut	2	1/2"	28	153-044	Decal	1	Important
9	348-205	Pin	2	---	29	153-528	Decal	1	Warning - Hyd. pressure
10	348-198	Safety Stop	1	---	30	153-167	Decal	1	Danger - Pinch
11	104-251	Safety snap pin	1	3/8" x 4" x 4 3/4"	31	100-569	Bolt	2	1" x 3 1/2", Grade 5
12	194-464	Cylinder	1	6" x 6" welded	32	108-025	Lock washer	4	1"
13	348-179	Pin	1	---	33	102-214	Lock nut	4	1" Nylock
14	100-305	Flange bolt	2	1/2" x 1", Grade 8	34	130-037	Safety Chain	2	CAT4
15	348-197	Pin	1	---	35	100-405	Bolt	2	1" x 7 1/2", Grade 8
16	100-306	Bolt	2	1/2" x 2 3/4", Grade 8	36	348-811	Hydraulic storage	1	
17	102-224	Lock nut	2	1/2"	37	152-806	Hitch Tab	1	CAT4 (2" tractor pin)
18	505-379	Collar	2	---		152-805			CAT5 (2 3/4" tractor pin)
19	198-246	Elbow	2	7/8MB x 3/4MJ 90 degrees	38	505-854	Pin and cotter key	1	
20	196-352	Hydraulic Hose	4	1/2" x 132"	39	153-627	Decal	1	Danger

PARTS IDENTIFICATION

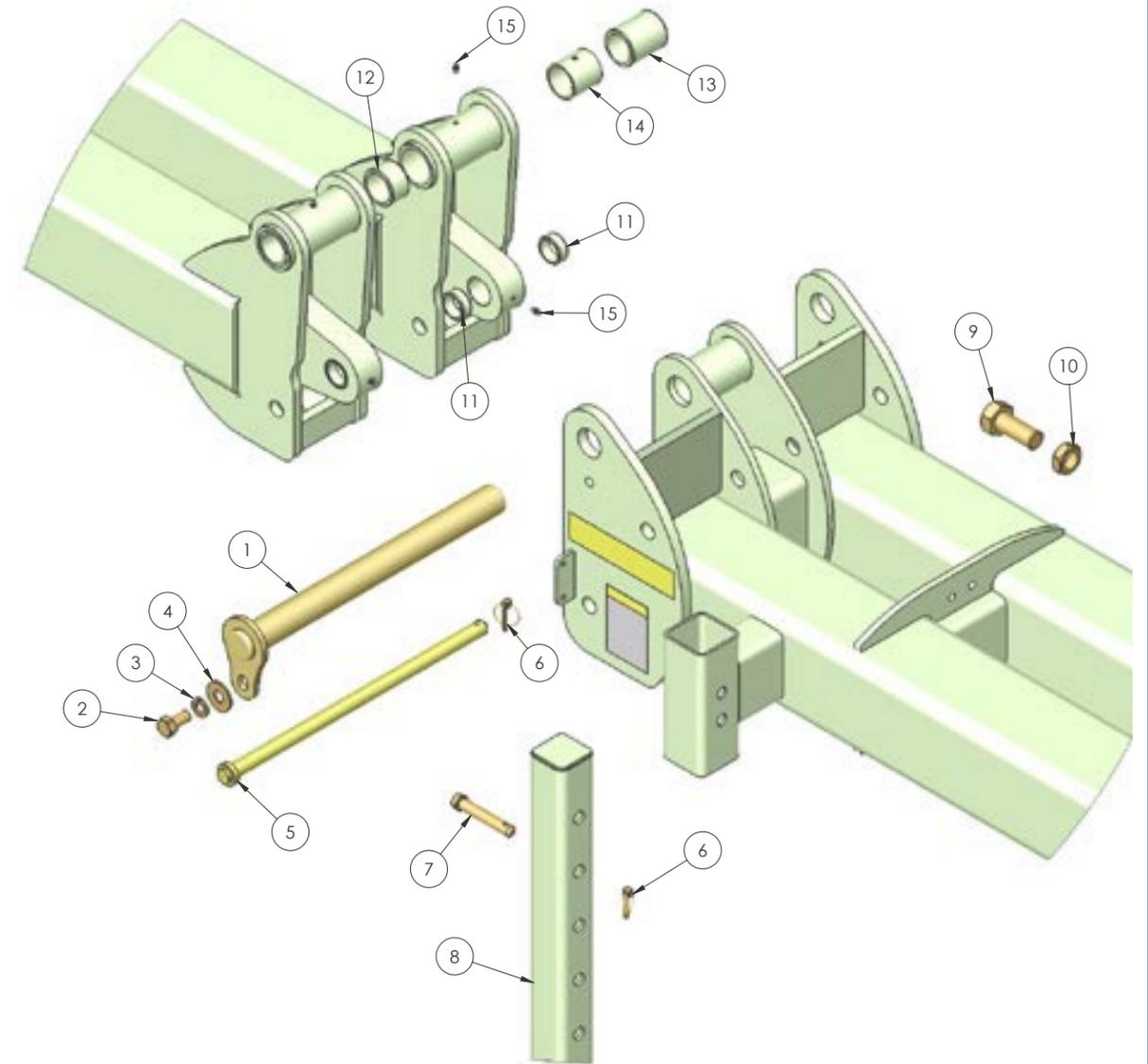

TOOLBAR HINGE ASSEMBLY

Key	Part #	Description	Qty	Notes	Key	Part #	Description	Qty	Notes
1	342-810	Hinge pin	2	2" x 22" long	9	100-471	Bolt	4	1 1/4" x 3", Grade 8
2	100-206	Bolt	2	3/4" x 1 1/2", Grade 5	10	102-077	Jam nut	4	1 1/4"
3	108-022	Lock washer	2	3/4"	11	134-040	Bushing, split	8	1 7/8" x 1 1/2" x 3/4" long
4	108-011	Flat washer	2	3/4"	12	134-097	Bushing, split	4	2 1/2" x 2" x 1 1/2" long
5	342-809	Lock pin	2	1" x 22 7/16" long	13	134-094	Bushing, split	4	2 1/2" x 2" x 3" long
6	104-065	Lynch pin	4	5/16" x 1 11/16"	14	341-651	Spacer	4	2 3/8" long
7	303-846	Barstand pin	2	3/4" x 5" long	15	110-001	Grease fitting	8	1/4" straight
8	303-744	Bar stand	2	48"					

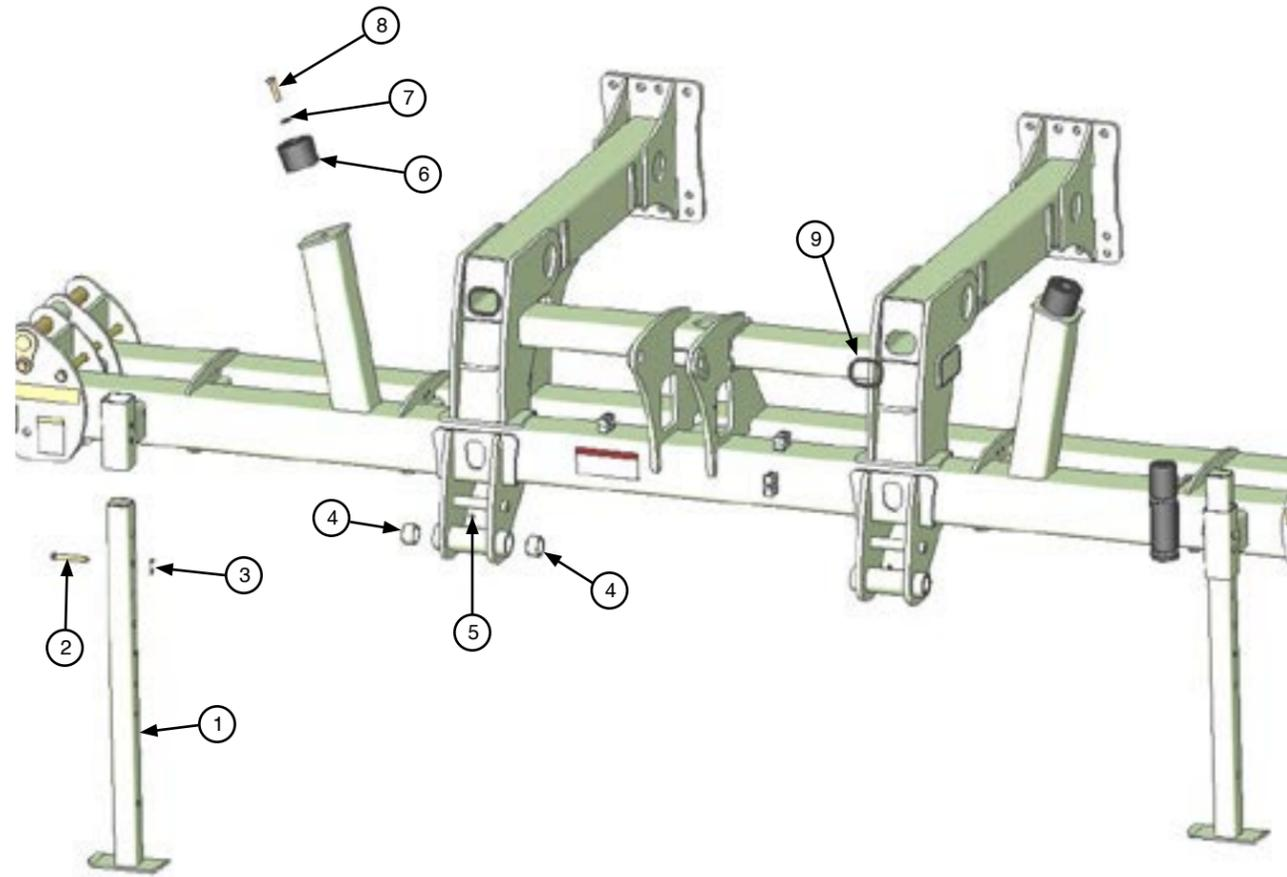

TOOLBAR CENTER SECTION ASSEMBLY

Key	Part #	Description	Qty	Notes
1	303-744	Bar stand	2	----
2	303-846	Pin	2	----
3	104-065	Lynch pin	2	----
4	134-097	Bushing	4	----
5	110-002	Grease fitting	2	----
6	152-588	Wing rest bumper	2	----
7	108-003	Flat washer	2	3/4"
8	100-075	Bolt	2	3/4" x 2 1/2"
9	352-075	Edge guard	2	Cut to length

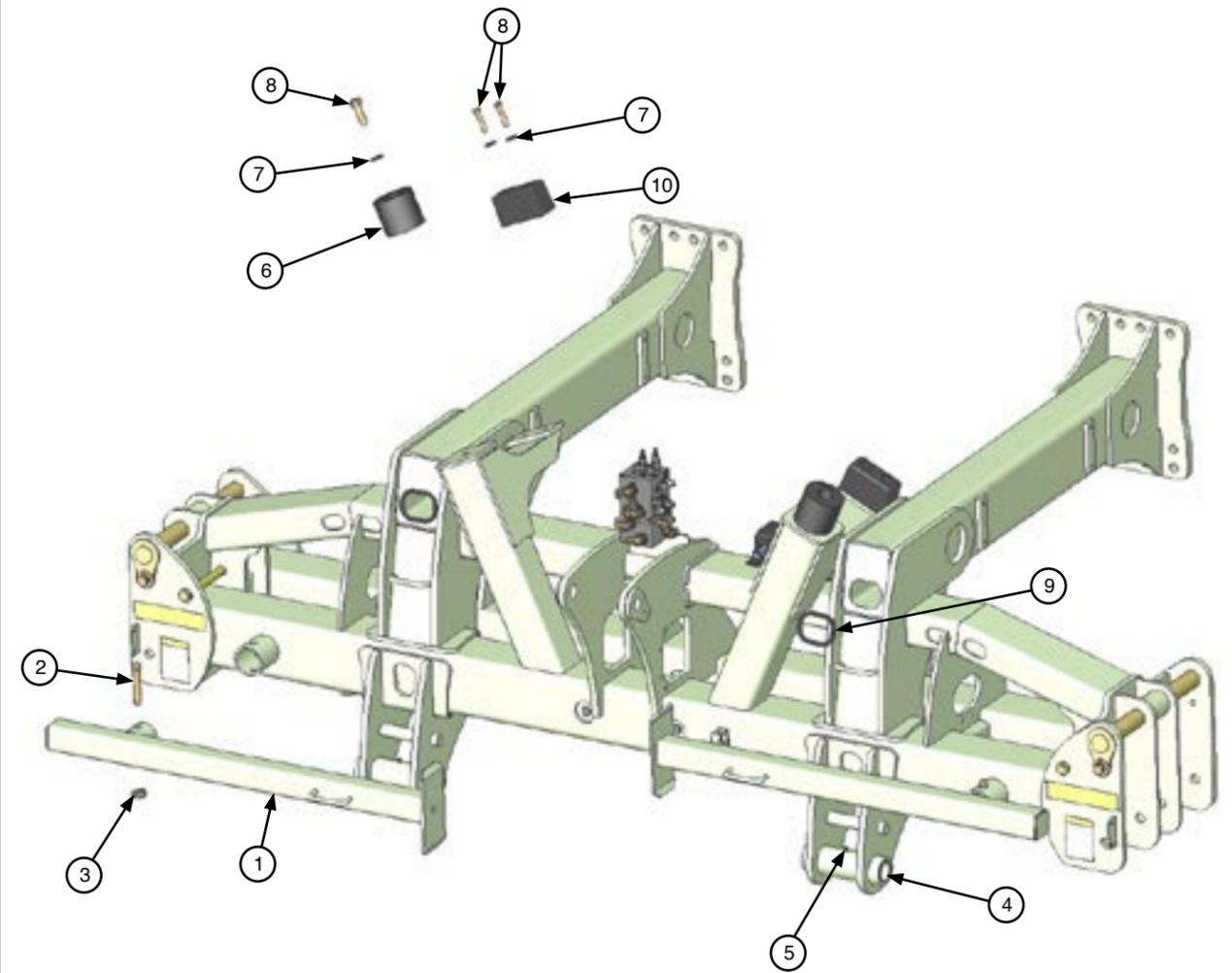

NT TOOLBAR CENTER SECTION ASSEMBLY

Key	Part #	Description	Qty	Notes
1	303-746	Bar stand	2	----
2	303-846	Pin	2	----
3	104-065	Lynch pin	2	----
4	134-097	Bushing	4	----
5	110-002	Grease fitting	2	----
6	152-588	Wing rest bumper	2	----
7	108-003	Flat washer	6	3/4"
8	100-075	Bolt	6	3/4" x 2 1/2"
9	352-075	Edge guard	2	Cut to length
10	152-027	Wing rest bumper	2	----

CARRIER ASSEMBLY

Key	Part #	Description	Qty	Notes	Key	Part #	Description	Qty	Notes
1		Main Frame		Identification Only	16	100-116	Bolt	2	1/2"-13 x 1 1/2"
2	348-448	Carrier Mount	2		17	108-020	Lock Washer	2	1/2"
3	348-412	Top Lift Arm	4		18	108-001	Flat Washer	2	1/2"
4	348-410	Bottom Lift Arm	2		19	100-305	Bolt	2	1/2"-13 x 1"
5	194-584	Cylinder	2	4x20", 9" Stroke	20	366-756	Bushing	2	
6	309-157	Pin	4	Lower Arm Pivot	21	100-122	Bolt	4	3/8"-24 x 2 1/2"
7	366-113	Pin	2	Base End	22	102-028	Nut	4	Lock, 1/2"
8	351-655	Pin	2	Rod End	23	100-305	Bolt	2	1/2"-13 x 1"
9	366-759	Pin	8	Top Arms	24	366-756	Bushing	2	
10	100-195	Bolt	24	1-8 x 3 1/4"	25	348-830	Safety Stop	2	
11	108-025	Lock Washer	24	1"	26	348-519	Axle Package	2	Used with 14.9R46 Wheels
12	102-111	Hex Nut	24	1"	26	100-446	Bolt	16	1" also Lock Washer, Hex Nut
13	100-116	Bolt	2	1/2"-13 x 1 1/2"	27	348-517	Axle Package	2	Used with 480/80R50 Wheels
14	108-020	Lock Washer	2	1/2"	27	100-446	Bolt	16	1" also Lock Washer, Hex Nut
15	108-001	Flat Washer	2	1/2"	28	190-100	Wheels	2	14.9R46 Wheels and Tires
					28	190-148	Wheels	2	480/80R50 Wheels and Tires

NT OUTER WING HINGE ASSEMBLY

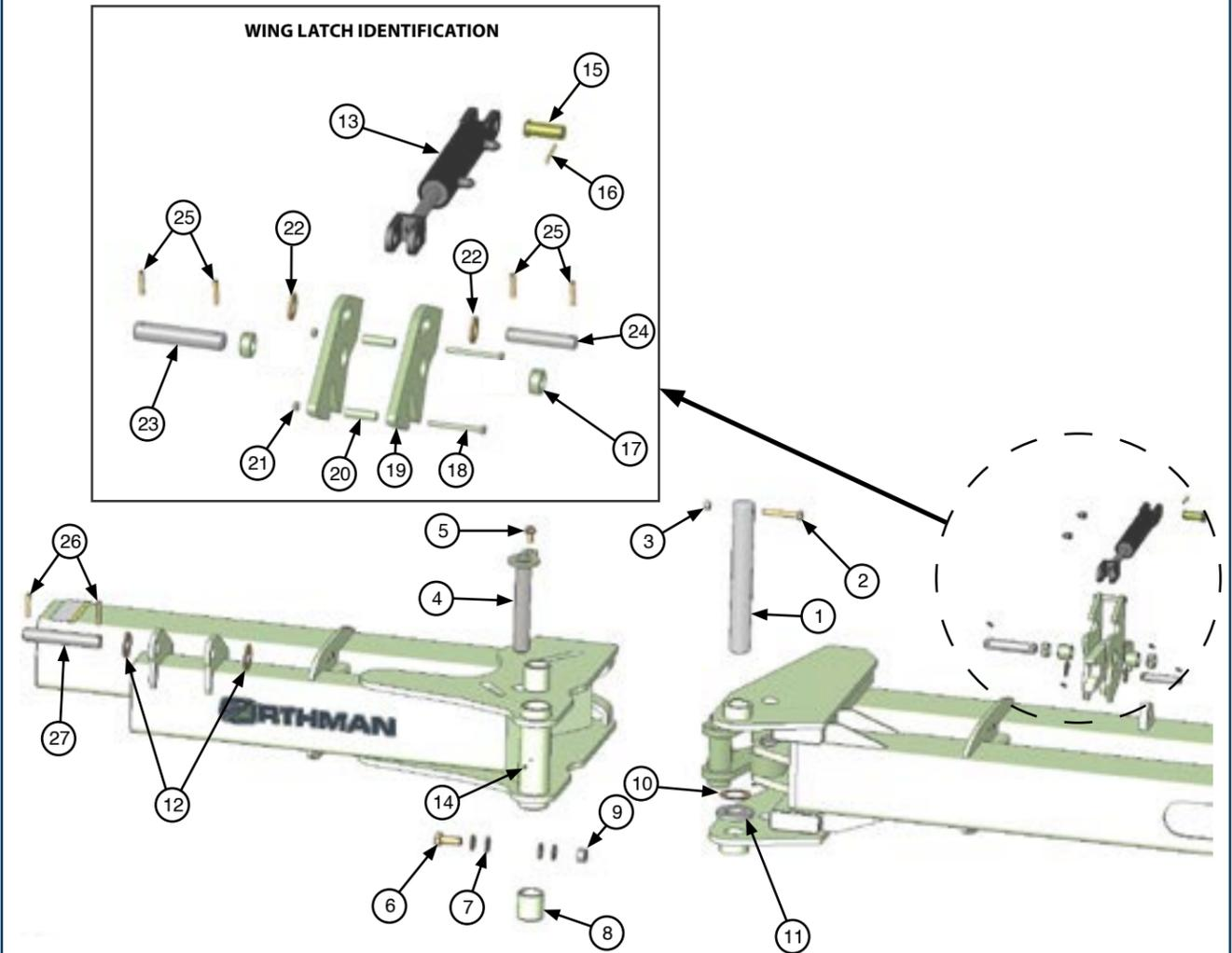

Parts list located on the following page.

NT OUTER WING HINGE ASSEMBLY

Key	Part #	Description	Qty	Notes	Key	Part #	Description	Qty	Notes
1	351-331	Hnge Pin	1	----	15	104-193	Pin	1	----
2	100-222	Stay bolt	1	1/2" x 3 1/2"	16	104-024	Cotter pin	1	----
3	102-028	Lock nut	1	1/2"	17	351-740	Bushing	2	----
4	351-725	Pin	1	----	18	100-321	Bolt	2	1/4" x 3"
5	152-588	Damper bolt	1	----	19	351-359	Wing latch plate	2	----
6	100-156	Wing stop bolt	1	3/4" x 2"	20	351-354	Spacer	2	----
7	108-003	Shim washer	4	3/4"	21	102-023	Nut	2	1/4"
8	351-312	Bushing	2	----	22	108-003	Flat washer	2	3/4"
9	351-361	Bushing	1	----	23	351-739	Pin	1	----
10	134-043	Bushing	1	----	24	351-748	Pin	1	----
11	120-177	Bearing	1	----	25	104-007	Roll pin	4	----
12	108-137	Flat washer	2	1 1/4"	26	104-014	Roll pin	2	----
13	194-403	Cylinder	1	----	27	351-747	Pin	1	----
14	110-001	Grease fitting	1	----					

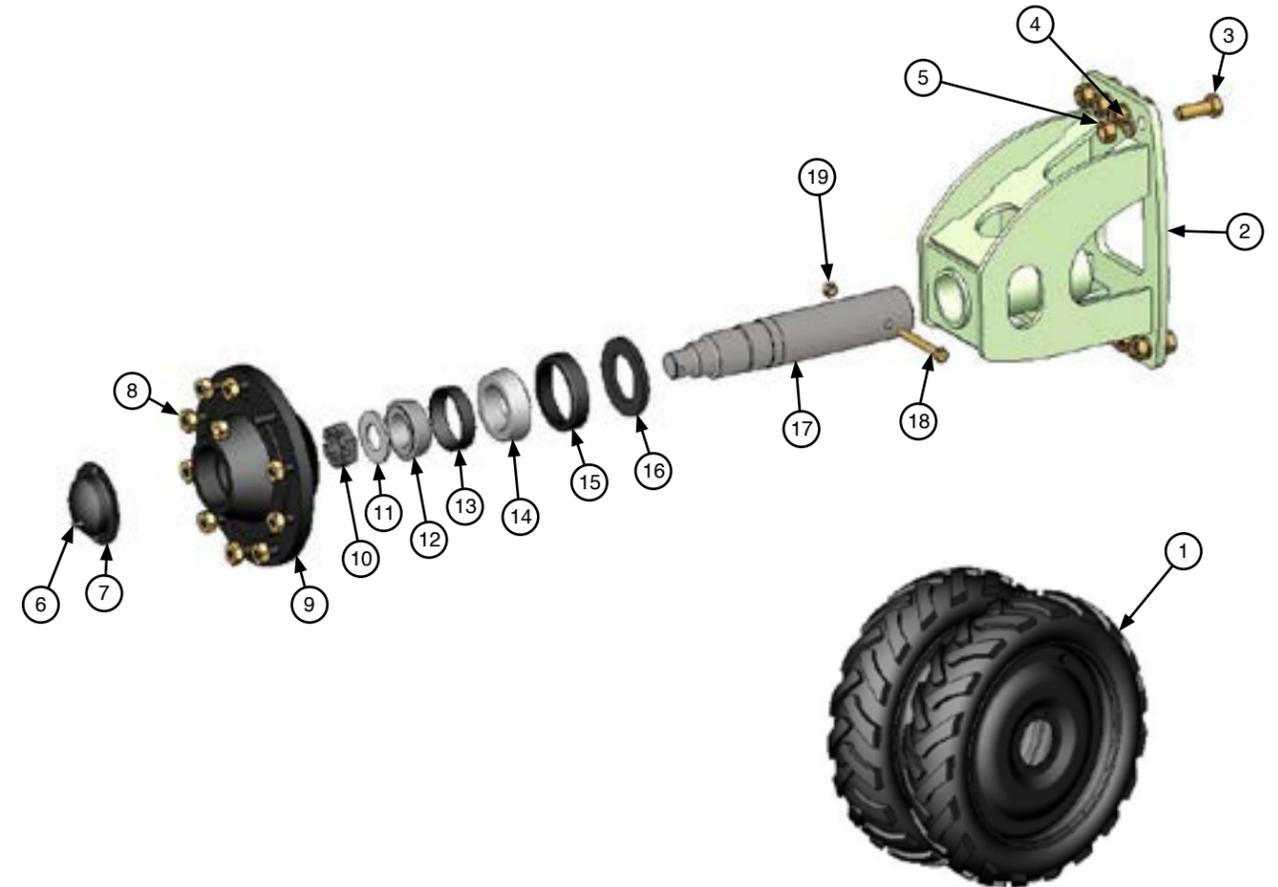

SMALL WHEEL AND AXLE PACKAGE

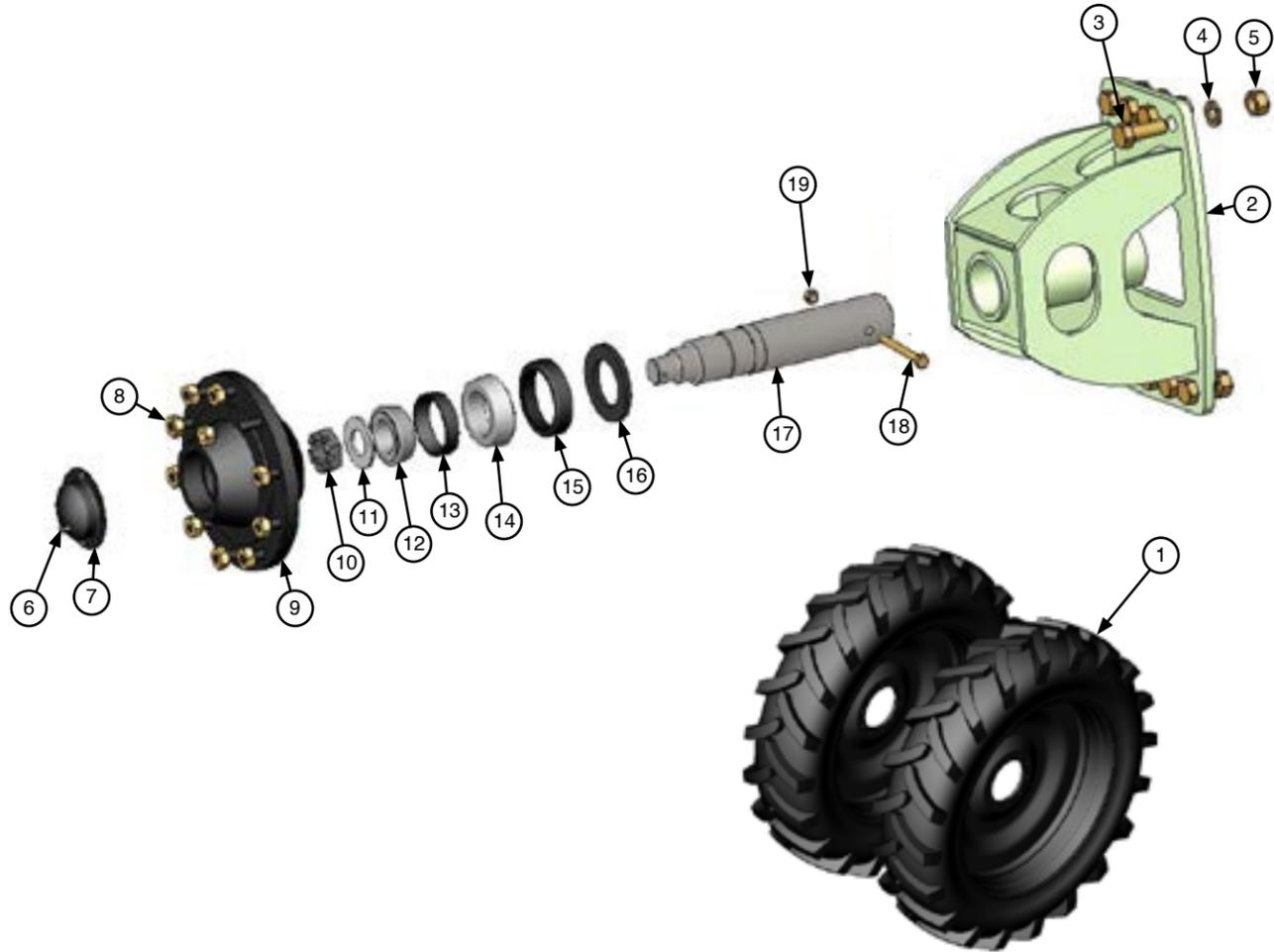
Key	Part #	Description	Qty	Notes	Key	Part #	Description	Qty	Notes
1	190-100	Tire and Rim	2	14.9R46	11	134-028	Washer	1	2 1/16" x 4" x 1/4"
2	348-640	Wheel Mount	2	----	12	120-085	Bearing	1	Small
3	100-446	Bolt	16	1"-8 x 2 3/4"	13	120-086	Race	1	Small
4	108-025	Lock Washer	16	1"	14	120-084	Bearing	1	Large
5	102-111	Hex Nut	16	1"	15	120-087	Race	1	Large
6	100-104	Bolt	4	5/16"/18 x 1/2"	16	150-142	Seal	1	-----
7	150-034	Dust Cap	1	----	17	188-026	Spindle	1	-----
8	102-089	Lug Nut	10	3/4" - 16	18	100-145	Bolt	1	5/8"-11 x 6 1/2"
9	170-042	Hub	1	Includes items 13 & 15	19	102-029	Lock Nut	1	5/8"
10	102-088	Slotted Nut	1	2" - 12					

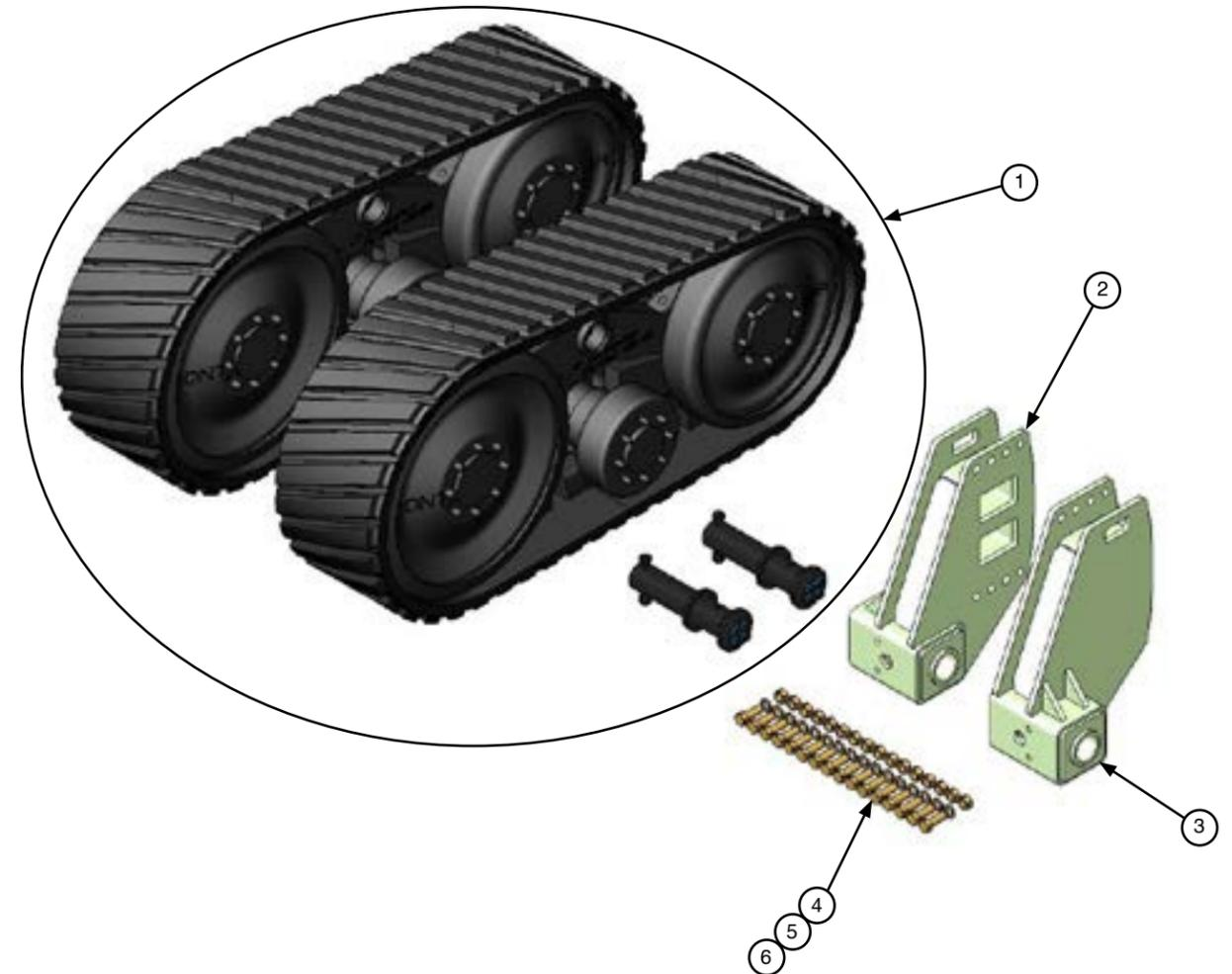

LARGE WHEEL AND AXLE PACKAGE

Key	Part #	Description	Qty	Notes	Key	Part #	Description	Qty	Notes
1	190-148	Tire and Rim	2	480/80R50	11	134-028	Washer	1	2 1/16" x 4" x 1/4"
2	348-510	Wheel Mount	2	----	12	120-085	Bearing	1	Small
3	100-446	Bolt	16	1"-8 x 2 3/4"	13	120-086	Race	1	Small
4	108-025	Lock Washer	16	1"	14	120-084	Bearing	1	Large
5	102-111	Hex Nut	16	1"	15	120-087	Race	1	Large
6	100-104	Bolt	4	5/16"/18 x 1/2"	16	150-142	Seal	1	-----
7	150-034	Dust Cap	1	----	17	188-026	Spindle	1	-----
8	102-089	Lug Nut	10	3/4" - 16	18	100-145	Bolt	1	5/8"-11 x 6 1/2"
9	170-042	Hub	1	Includes items 13 & 15	19	102-029	Lock Nut	1	5/8"
10	102-088	Slotted Nut	1	2" - 12					



CAMOPLAST TTS 30-1601 TRACK PACKAGE

Key	Part #	Description	Qty	Notes
1	190-160	Tracks and Axle Pins	-	Contact the Orthman parts department for individual replacement parts.
2	352-272	LH Axle Mount	1	----
3	352-271	RH Axle Mount	1	----
4	100-446	Bolt	16	1"-8 x 2 3/4"
5	108-025	Lock Washer	16	1"
6	102-111	Nut	16	Hex/ 1"

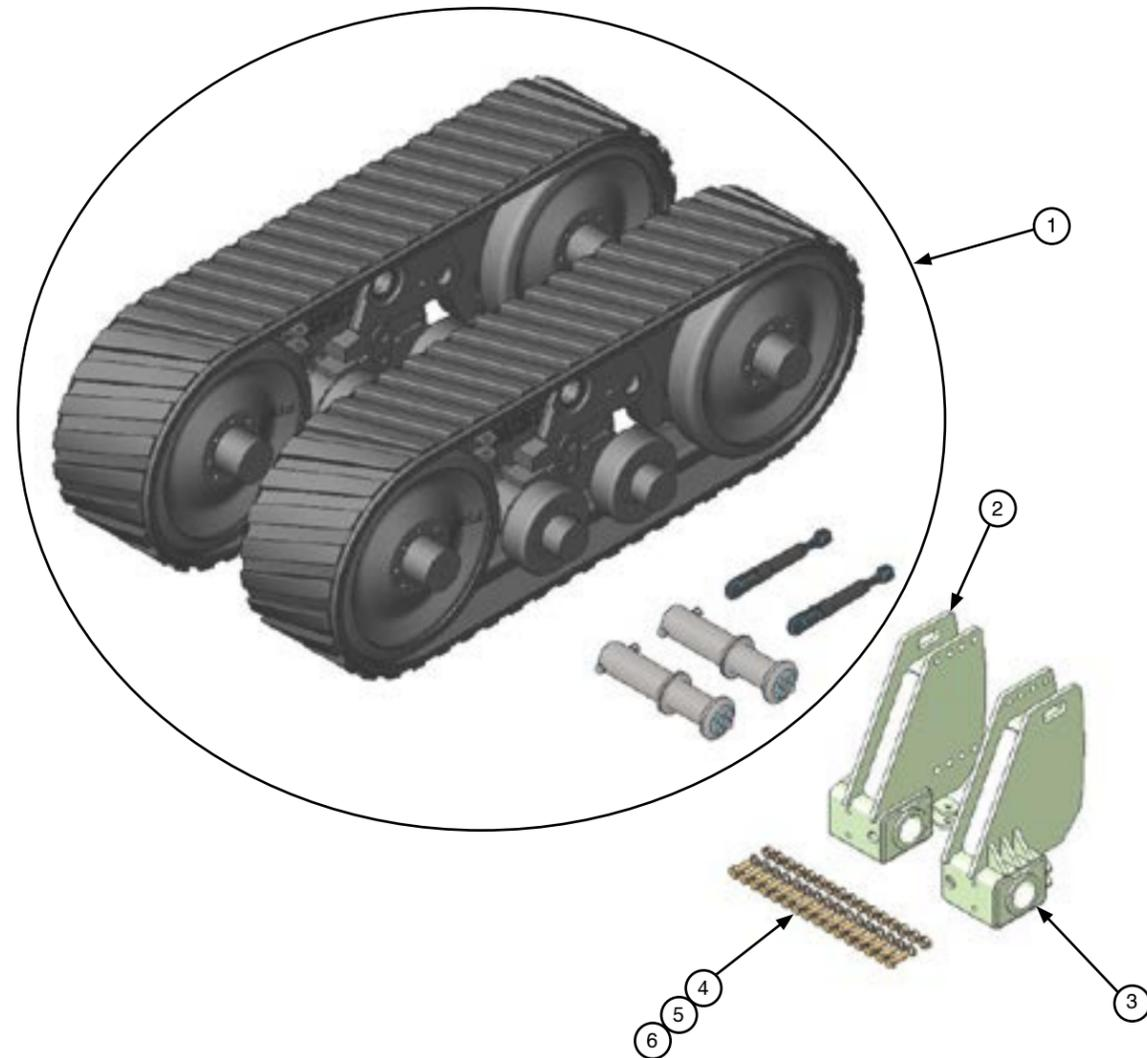

CAMOPLAST TTS 45-1811 TRACK SYSTEM

Key	Part #	Description	Qty	Notes
1	190-161	Tracks, Axle Pin, and Struts	1	Contact the Orthman parts department for individual replacement parts.
2	352-252	LH Axle Mount	1	----
3	352-251	RH Axle Mount	1	----
4	100-446	Bolt	16	1"-8 x 2 3/4"
5	108-025	Lock Washer	16	1"
6	102-111	Nut	16	Hex/ 1"

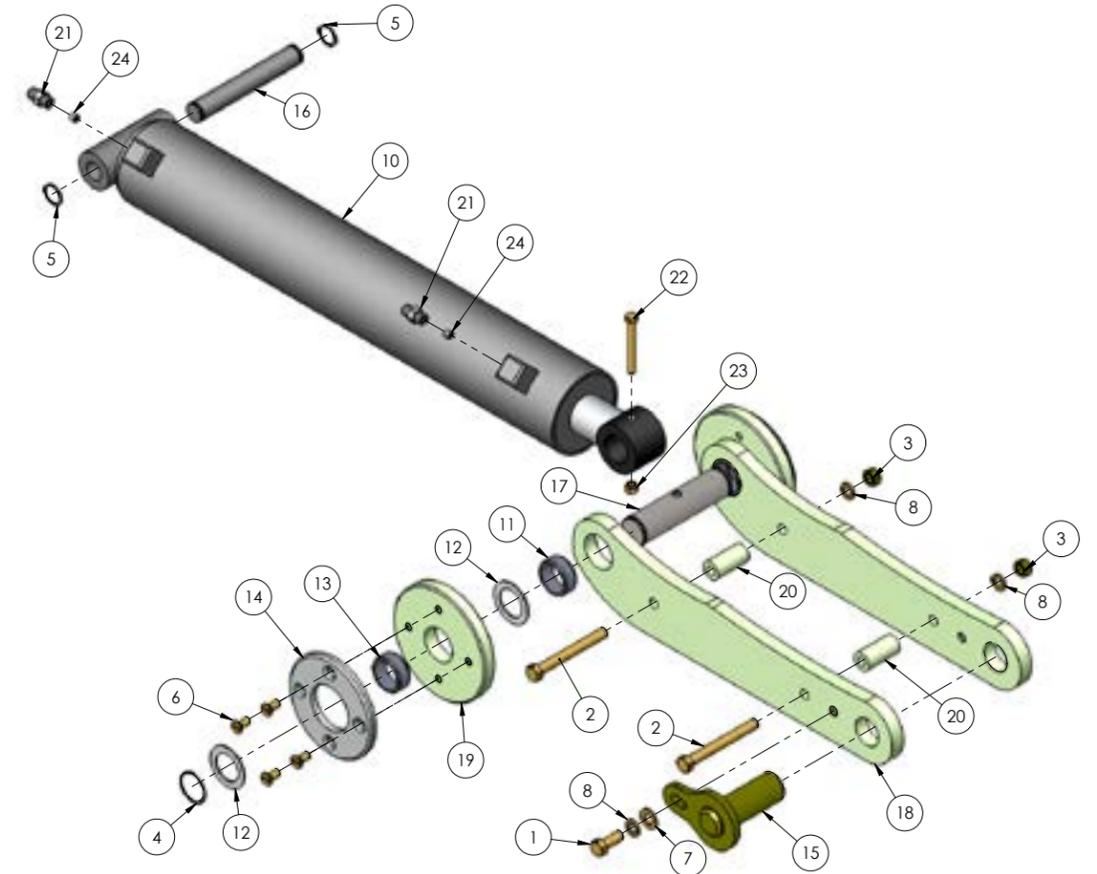

STANDARD INTERNAL FOLD ASSEMBLY

Key	Part #	Description	Qty	Notes
1	100-115	Bolt	1	1/2" x 1 1/4", Grade 5
2	100-125	Bolt	2	1/2" x 4 1/4", Grade 5
3	102-007	Nut	2	1/2"
4	104-052	Snap ring	2	1 1/2" external
5	104-053	Snap ring	2	1" external
6	106-107	Screw	4	3/8" x 3/4"
7	108-001	Flat washer	1	1/2"
8	108-020	Lock washer	3	1/2"
9				
10	194-499	Cylinder	1	4" x 24"
11	134-040	Bushing, split	2	1 7/8" x 1 1/2" x 3/4"
12	134-041	Machined washer	4	2 1/4" x 1 1/2" x 14 ga.
13	134-040	Bushing, split	2	1 7/8" x 1 1/2" x 3/4"
	134-047	Bushing, split	2	1 3/4" x 1 1/2" x 5/8"
14	301-512	Friction plate	2	---
15	301-548	Linkage pin	1	---
16	301-500	Pin	1	6 7/8" long (for 3/8" wall bars)
	301-800	Pin	1	6 9/16" long (for 1/2" wall bars)
17	301-948	Pin	1	5 7/8" long (for 3/8" wall bars)
	301-945	Pin	1	5 5/8" long (for 1/2" wall bars)
18	341-823	Connecting strap	2	---
19	301-511	Guide wheel	2	3/4" thick (for 3/8" wall bars)
	301-802	Guide wheel	2	5/8" thick (for 1/2" wall bars)
20	317-714	Spacer	2	---
21	340-078	Adaptor	2	9/16" MB x 9/16 MJ
22	100-098	Bolt	1	3/8" x 3", Grade 5
23	102-027	Lock nut	1	3/8"
24	340-057	Restrictor	2	3/8" x 3/8" with .055 hole

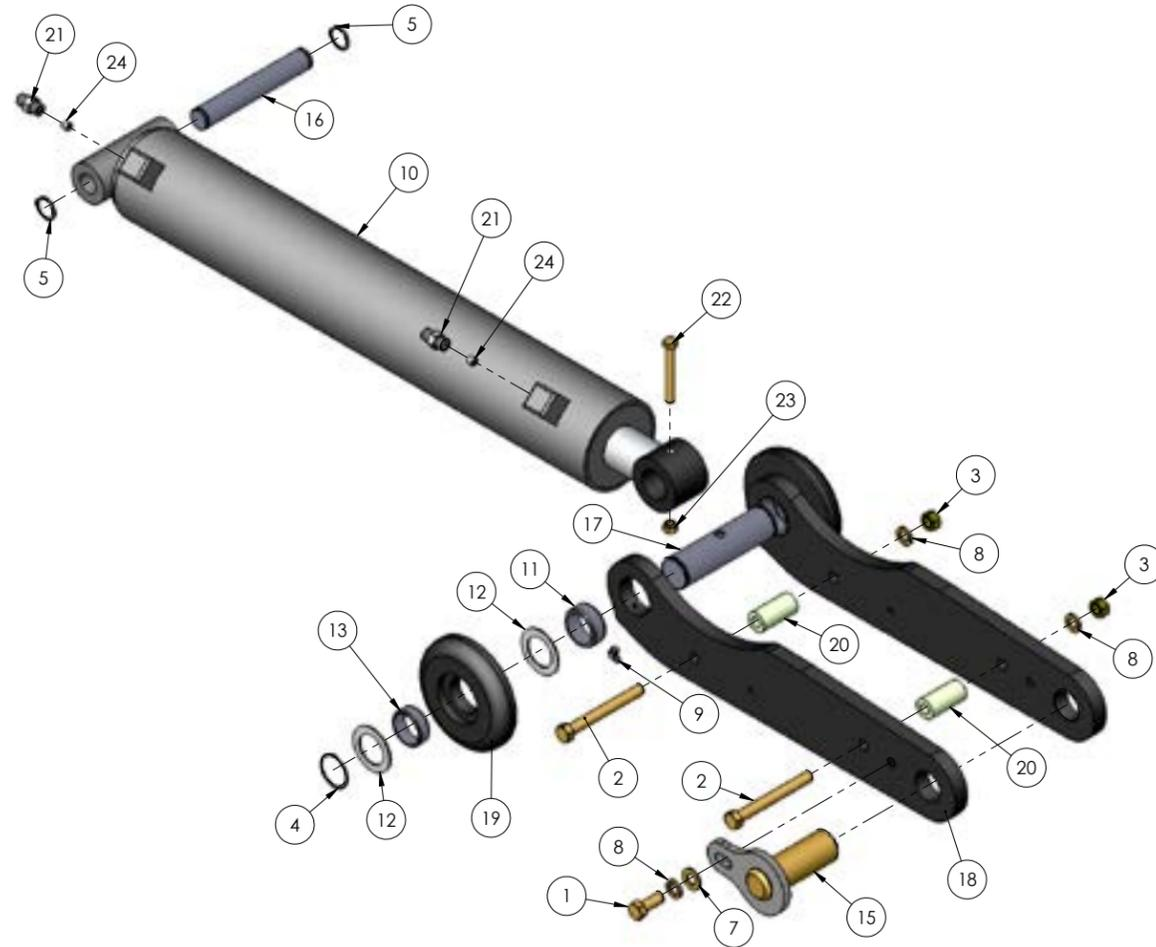

NT MID-WING INTERNAL FOLD ASSEMBLY

Key	Part #	Description	Qty	Notes	Key	Part #	Description	Qty	Notes
1	100-115	Bolt	1	1/2" x 1 1/4", Grade 5	13	134-047	Bushing, split	2	1 3/4" x 1 1/2" x 5/8"
2	100-125	Bolt	2	1/2" x 4 1/4", Grade 5	14	301-512	Friction plate	2	---
3	102-007	Nut	2	1/2"	15	301-548	Linkage pin	1	---
4	104-052	Snap ring	2	1 1/2" external	16	301-800	Pin	1	6 9/16" long (for 1/2" wall bars)
5	104-053	Snap ring	2	1" external	17	301-945	Pin	1	5 5/8" long (for 1/2" wall bars)
6	106-107	Screw	4	3/8" x 3/4"	18	301-502	Connecting strap	2	black
7	108-001	Flat washer	1	1/2"	19	301-802	Guide wheel	2	1" thick (for 1/2" wall bars)
8	108-020	Lock washer	3	1/2"	20	317-714	Spacer	2	---
9	110-008	Grease fitting	2	1/4" x 90 degrees	21	340-078	Adaptor	2	9/16" MB x 9/16 MJ
10	194-499	Cylinder	1	4" x 24"	22	100-098	Bolt	1	3/8" x 3", Grade 5
11	134-040	Bushing, split	2	1 7/8" x 1 1/2" x 3/4"	23	102-027	Lock nut	1	3/8"
12	134-041	Machined washer	4	2 1/4" x 1 1/2" x 14 ga.	24	340-057	Restrictor	2	3/8" x 3/8" with .055 hole

NT OUTER WING FOLD LINKAGE ASSEMBLY

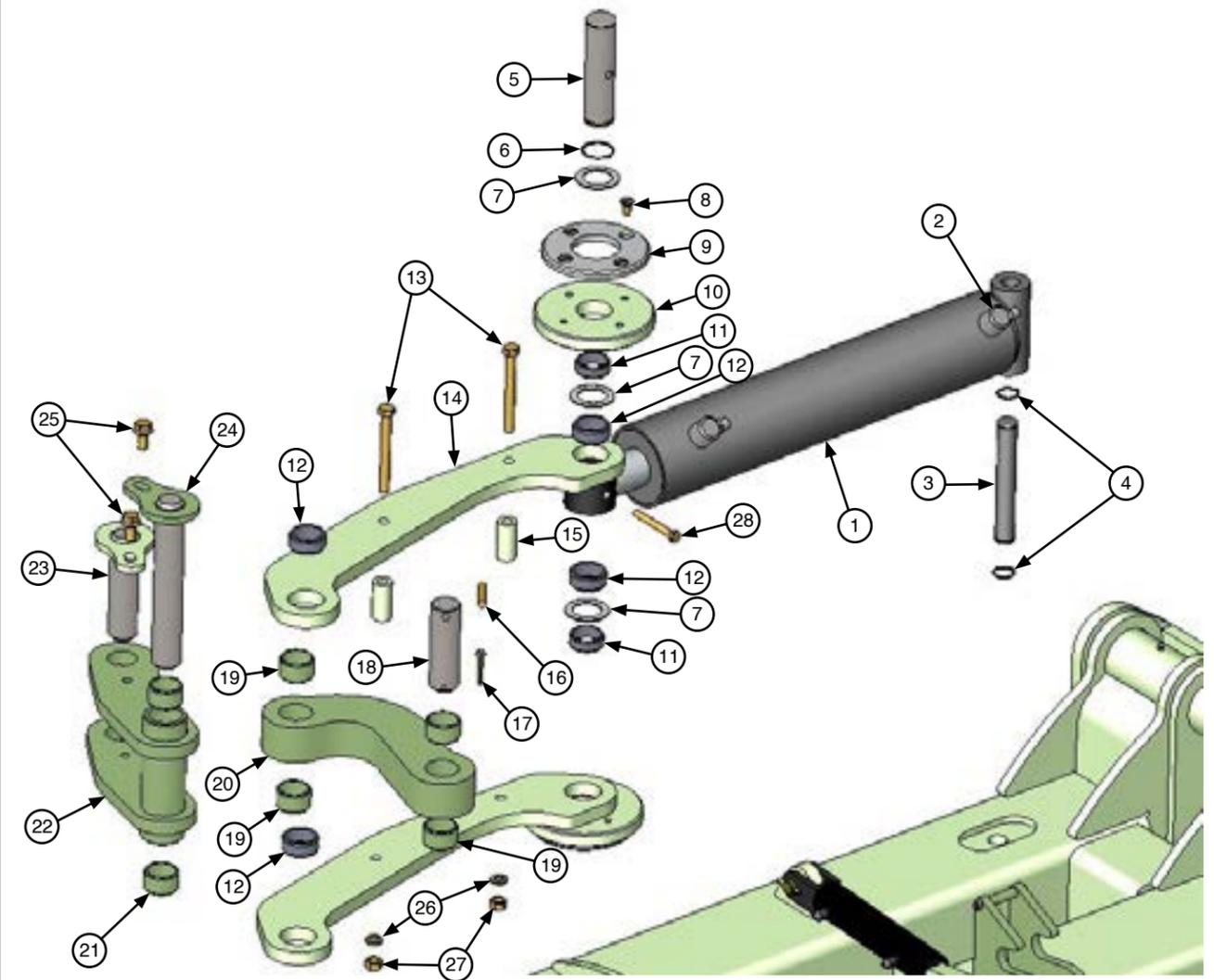

Parts list located on the following page.

NT OUTER WING FOLD LINKAGE ASSEMBLY

Key	Part #	Description	Qty	Notes	Key	Part #	Description	Qty	Notes
1	194-498	Cylinder	1	----	15	312-082	Bushing	2	2 1/16" length
2	340-078	Adaptor	2	9/16-18MB x 9/16MJ	16	390-070	Lock Pin	1	----
3	301-500	Cylinder Pin	1	----	17	104-022	Cotter pin	1	----
4	104-053	Snap Ring	2	----	18	351-742	Pin	1	----
5	301-948	Cylinder Pin	1	----	19	134-017	Bushing	4	----
6	104-052	Snap Ring	2	----	20	351-396	Wing fold link	1	----
7	134-041	Bushing	4	----	21	134-017	Bushing	2	----
8	106-107	Screw	8	----	22	351-397	Wing Fold link	1	----
9	301-512	Friction Plate	2	----	23	351-725	Fold link pin	1	----
10	301-982	Guide Wheel	2	----	24	351-724	Fold link pin	1	----
11	134-047	Bushing	2	----	25	100-305	Stay bolt	2	1/2" x 1"
12	134-040	Bushing	4	----	26	108-020	Flat washer	2	1/2"
13	100-125	Bolt	2	1/2" x 4 1/2"	27	102-007	Nut	2	1/2"
14	351-394	Wing fold link	2	----	28	100-098	Bolt	1	3/8" x 3"

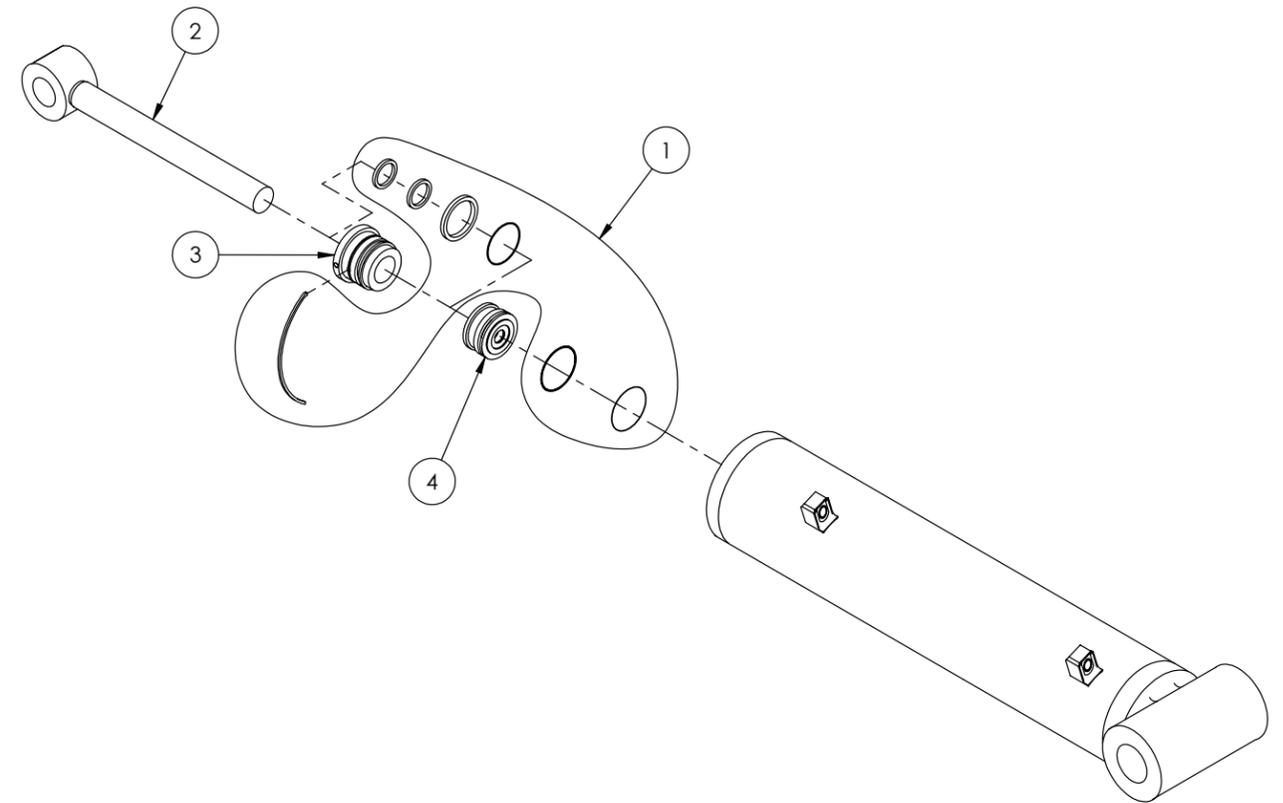

HYDRAULIC CYLINDER (WING FOLD)

Key	Part #	Description	Qty	Notes
1	194-440	Seal kit	1	for 194-499 cylinder
2	194-406	Cylinder rod	1	---
3	194-288	Gland	1	---
4	194-293	Piston	1	---

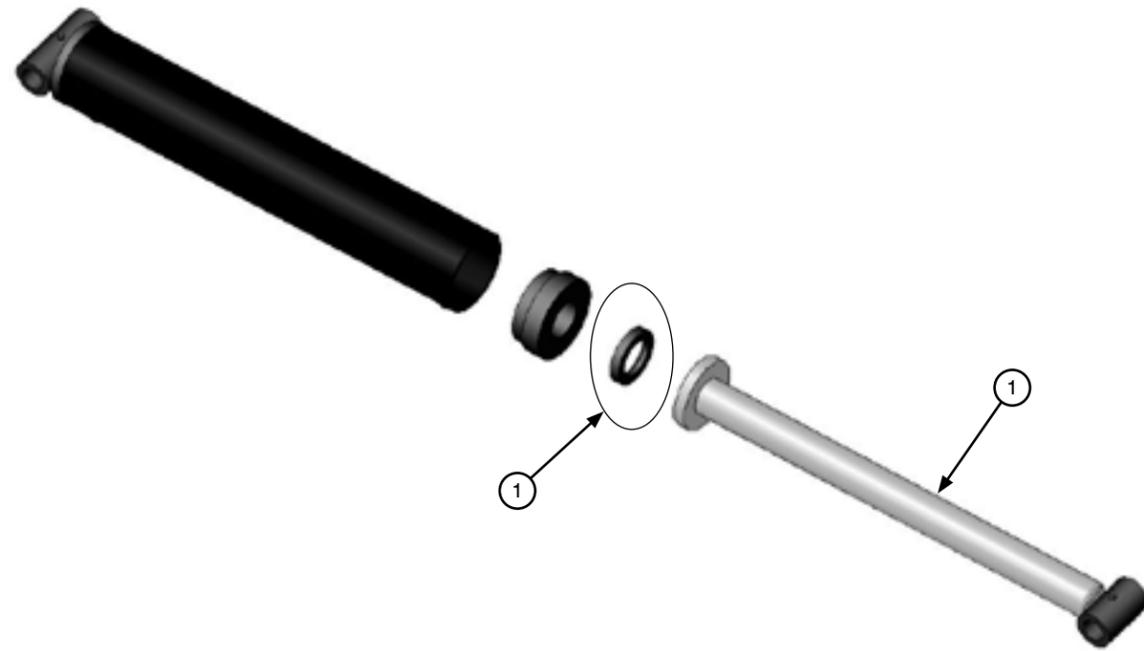

HYDRAULIC CYLINDER (MACHINE LIFT)

Key	Part #	Description	Qty	Notes
1	194-585	Seal kit	1	for 194-584 cylinder
2	194-586	Cylinder rod	1	---

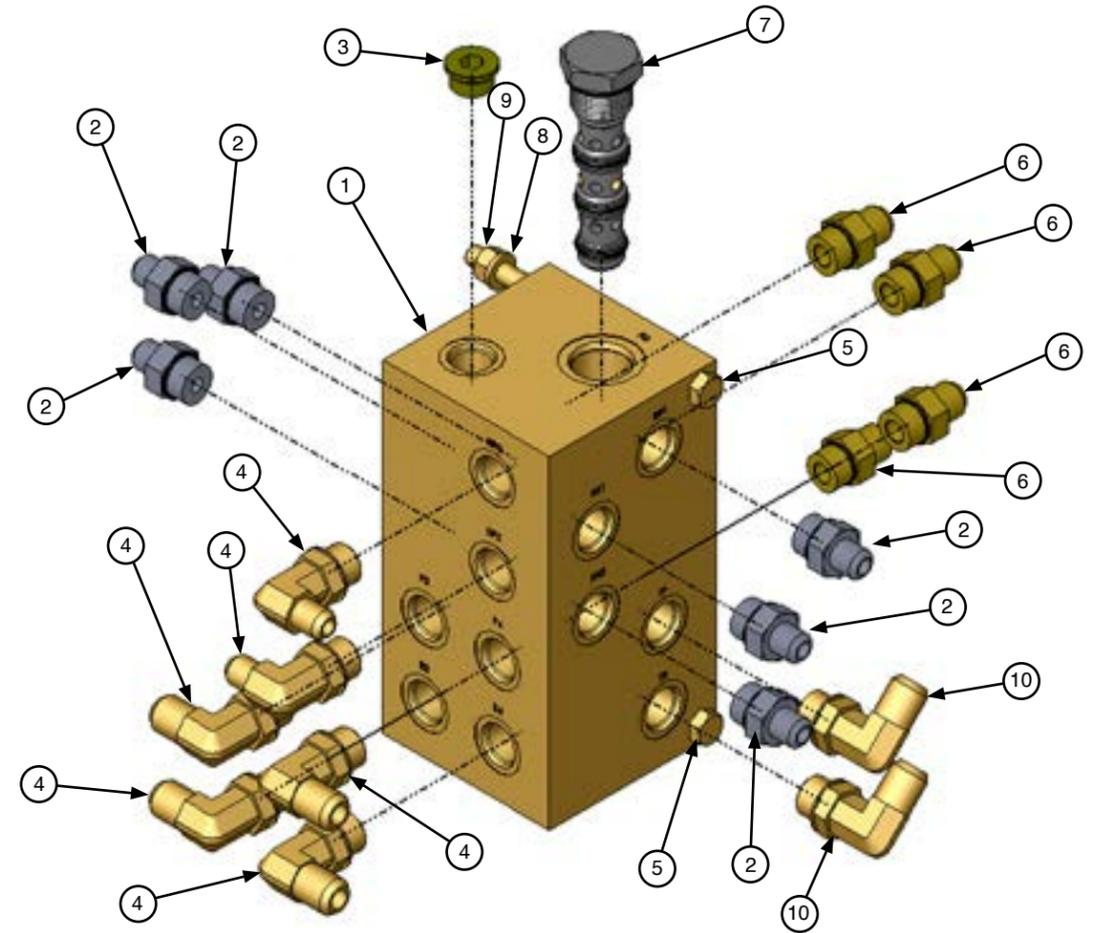

STANDARD HYDRAULIC MANIFOLD ASSEMBLY

Key	Part #	Description	Qty	Notes
1	180-332	Manifold block	1	no fittings
2	198-078	Adaptor	6	3/4 - 16MB - 9/16-18MJ
3	198-210	Plug	1	3/4 - 16MB
4	198-089	Elbow	6	3/4 - 16MB - 3/4 - 16MJ
5	100-215	Bolt	2	3/8 - 16 x 5 1/2 GR. 5
6	198-128	Adaptor	4	3/4-16MB - 3/4MJ
7	180-279	Flow Divider	1	----
8	108-018	Lock Washer	2	3/8
9	102-005	Nut	2	3/8-16 GR. 2
10	198-064	Elbow	2	3/4-16MB - 9/16-18MJ

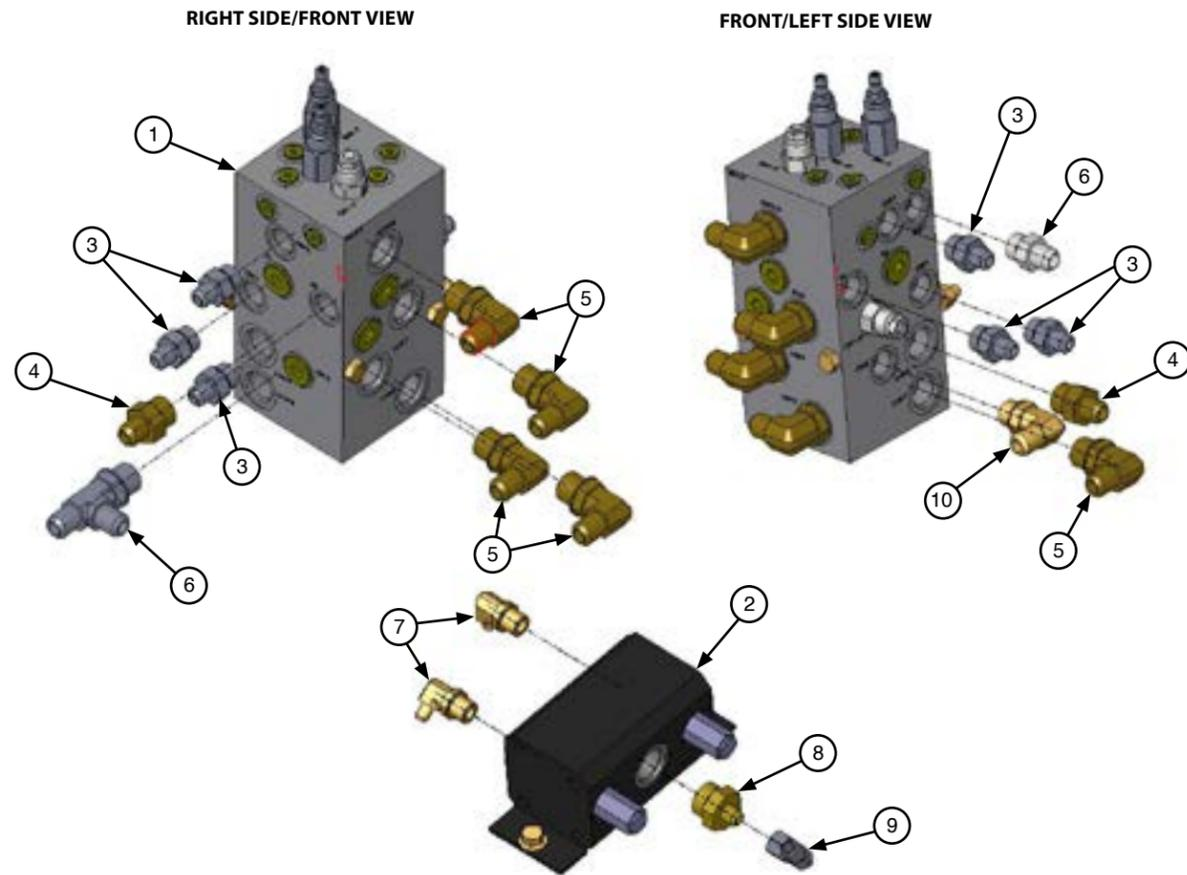

NT HYDRAULIC MANIFOLD/GEAR FLOW DIVIDER ASSEMBLY

Key	Part #	Description	Qty	Notes
1	180-310	Manifold block	1	no fittings
2	180-289	Gear Flow Divider	1	-----
3	198-078	Adaptor	6	3/4-16MB - 9/16-18MJ
4	198-109	Adaptor	3	7/8-14MB - 3/4-16MJ
5	198-246	Elbow	5	7/8-14MB - 3/4-16MJ
6	198-128	Adaptor	1	3/4-16MB - 3/4MJ
7	198-080	Elbow	2	7/8-14MB - 9/16-18MJ
8	198-289	Adaptor	1	5/16-12MB - 3/4-16MJ
9	198-301	Elbow	1	3/4-16MJ - 3/4FJX
10	198-089	Elbow	1	3/4-16MJ - 3/4-16MJ

**HYDRAULIC HOSE IDENTIFICATION
(STANDARD WING FOLD)**

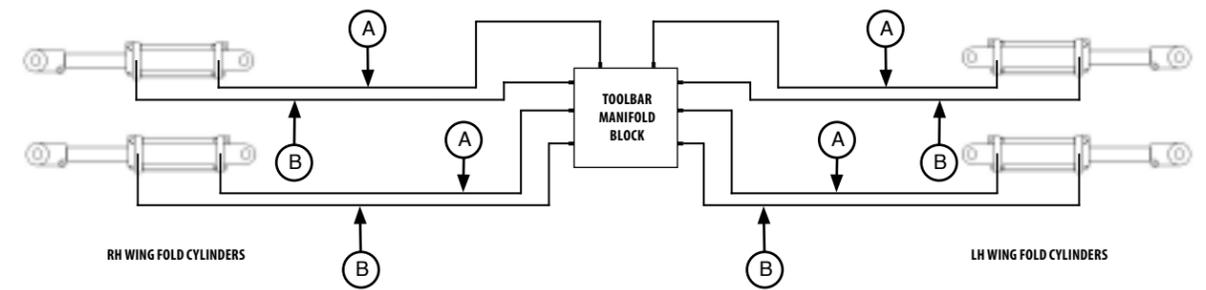

Parts list located on the following page.

STANDARD WING FOLD HYDRAULIC HOSES

Key	Part #	Machine Configuration	Qty	Notes
A	301-454	8R30	2	1/4" x 48"; Wing Extend Hyd. Hose
		End fittings		9/16FJX x 9/16FJX
B	196-112	8R30	2	1/4" x 72"; Wing Retract Hyd. Hose
		End fittings		9/16FJX x 9/16FJX
A	196-112	12R30	2	1/4" x 72"; Wing Extend Hyd. Hose
		End fittings		9/16FJX x 9/16FJX
B	196-113	12R30	2	1/4" x 96"; Wing Retract Hyd. Hose
		End fittings		9/16FJX x 9/16FJX
A	196-113	12R36	4	1/4" x 96"; Wing Extend Hyd. Hose
		End fittings		9/16FJX x 9/16FJX
B	196-114	12R36	4	1/4" x 120"; Wing Retract Hyd. Hose
		End fittings		9/16FJX x 9/16FJX
A	196-141	16R30	4	1/4" x 108"; Wing Extend Hyd. Hose
		End fittings		9/16FJX x 9/16FJX
B	196-118	16R30	4	1/4" x 132"; Wing Retract Hyd. Hose
		End fittings		9/16FJX x 9/16FJX
A	196-118	16R36	4	1/4" x 132"; Wing Extend Hyd. Hose
		End fittings		9/16FJX x 9/16FJX
B	196-454	16R36	4	1/4" x 156"; Wing Retract Hyd. Hose
		End fittings		9/16FJX x 9/16FJX
A	196-118	18R30	4	1/4" x 132"; Wing Extend Hyd. Hose
		End fittings		9/16FJX x 9/16FJX
B	196-454	18R30	4	1/4" x 156"; Wing Retract Hyd. Hose
		End fittings		9/16FJX x 9/16FJX

Note: Tongue hydraulic hoses can be found on the "Tongue Assembly" parts pages.

**HYDRAULIC HOSE IDENTIFICATION
(NARROW TRANSPORT WING FOLD)**

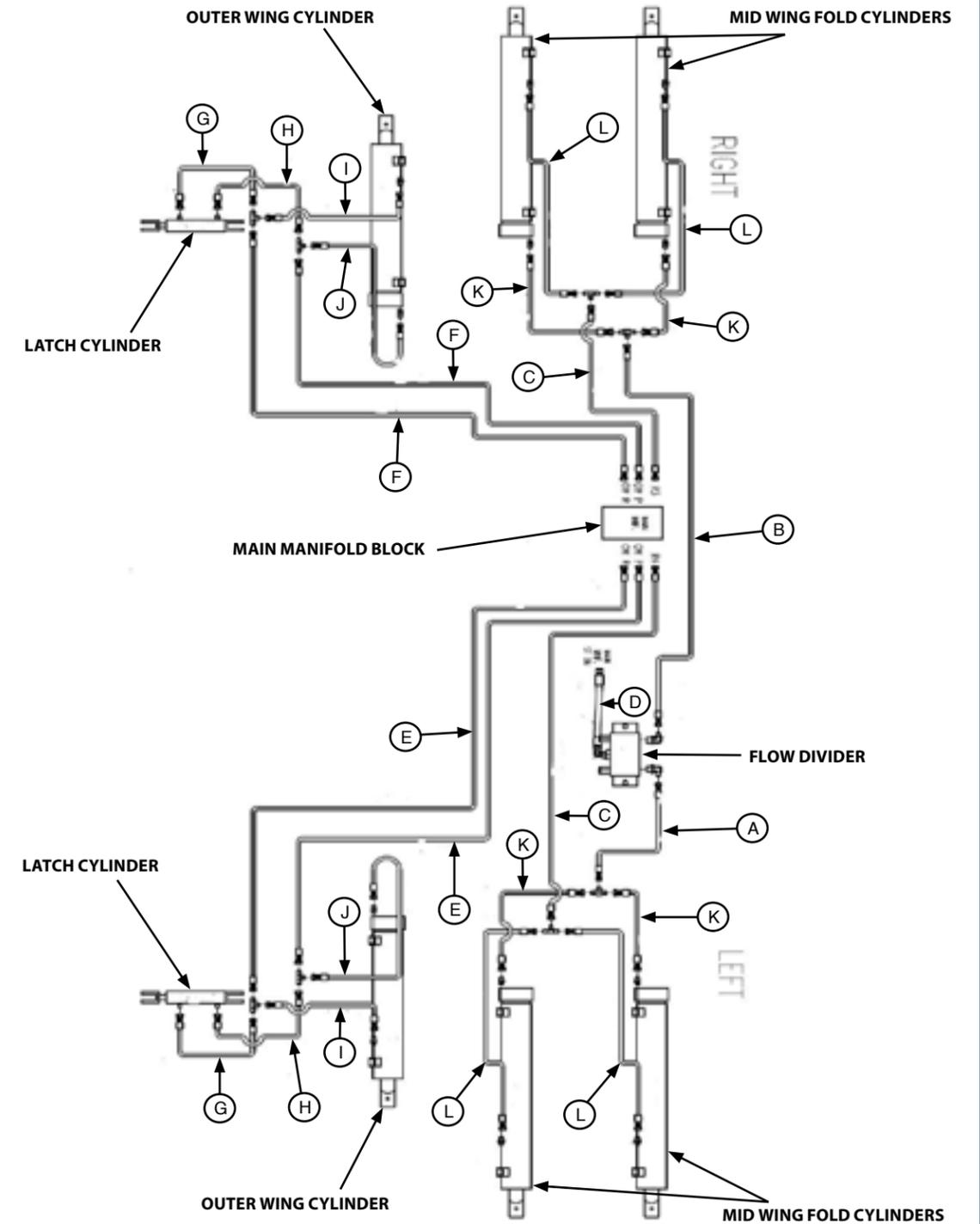

NARROW TRANSPORT TOOLBAR HYDRAULIC HOSE

Key	Machine	Part #	LT	Qty	Notes	Machine	Part #	LT	Qty	Notes
A	12R30NT	320-317	18"	1	Fold Divider to Tee (LH Pressure) 3/8"; 9/16FJX	16R30NT 18R30NT	333-287	20"	1	Fold Divider to Tee (LH Pressure) 3/8"; 9/16FJX
B	12R30NT	196-445	23"	1	Fold Divider to Tee (RH Pressure) 3/8"; 9/16FJX	16R30NT 18R30NT	196-047	28"	1	Fold Divider to Tee (RH Pressure) 3/8"; 9/16FJX
C	12R30NT	196-047	28"	2	Manifold To Tee (Retract) 3/8"; 9/16FJX	16R30NT 18R30NT	196-047	28"	2	Manifold To Tee (Retract) 3/8"; 9/16FJX
D	12R30NT	196-505	16"	1	Manifold to Fold Divider (Pressure) 1/2"; 3/4FJX	16R30NT 18R30NT	196-505	16"	1	Manifold to Fold Divider (Pressure) 1/2"; 3/4FJX
E	12R30NT	196-141	108"	2	Manifold to LH Outer Wing Tee 1/4"; 9/16 FJX	16R30NT 18R30NT	196-119	144"	2	Manifold to LH Outer Wing Tee 1/4"; 9/16 FJX
F	12R30NT	196-113	96"	2	Manifold to RH Outer Wing Tee 1/4"; 9/16 FJX	16R30NT 18R30NT	196-118	132"	2	Manifold to RH Outer Wing Tee 1/4"; 9/16 FJX
G	12R30NT	302-847	16"	2	Latch Cylinder Rod End to Tee 1/4"; 9/16 FJX	16R30NT 18R30NT	301-467	53"	2	Outer Wing Cylinder Rod End to Tee 1/4"; 9/16 FJX
H	12R30NT	305-148	22.5"	2	Latch Cylinder Base End to Tee 1/4"; 9/16 FJX	16R30NT 18R30NT	305-148	22.5"	2	Outer Wing Cylinder Base End to Tee 1/4"; 9/16 FJX
I	12R30NT	318-520	12.5"	2	Outer Wing Cylinder Rod End to Tee 1/4"; 9/16 FJX	16R30NT 18R30NT	305-148	22.5"	2	Latch Cylinder Rod End to Tee 1/4"; 9/16 FJX
J	12R30NT	318-522	29.5"	2	Outer Wing Cylinder Base End to Tee 1/4"; 9/16 FJX	16R30NT 18R30NT	305-307	27.5"	2	Latch Cylinder Base End to Tee 1/4"; 9/16 FJX
K	12R30NT	318-522	29.5"	4	Inner Wing Cylinder Base End to Tee 1/4"; 9/16 FJX	16R30NT 18R30NT	196-515	39"	4	Inner Wing Cylinder Base End to Tee 1/4"; 9/16 FJX
L	12R30NT	318-523	58"	4	Inner Wing Cylinder Rod End to Tee 1/4"; 9/16 FJX	16R30NT 18R30NT	301-466	68"	4	Inner Wing Cylinder Rod End to Tee 1/4"; 9/16 FJX

**HYDRAULIC HOSE IDENTIFICATION
(MACHINE LIFT)**

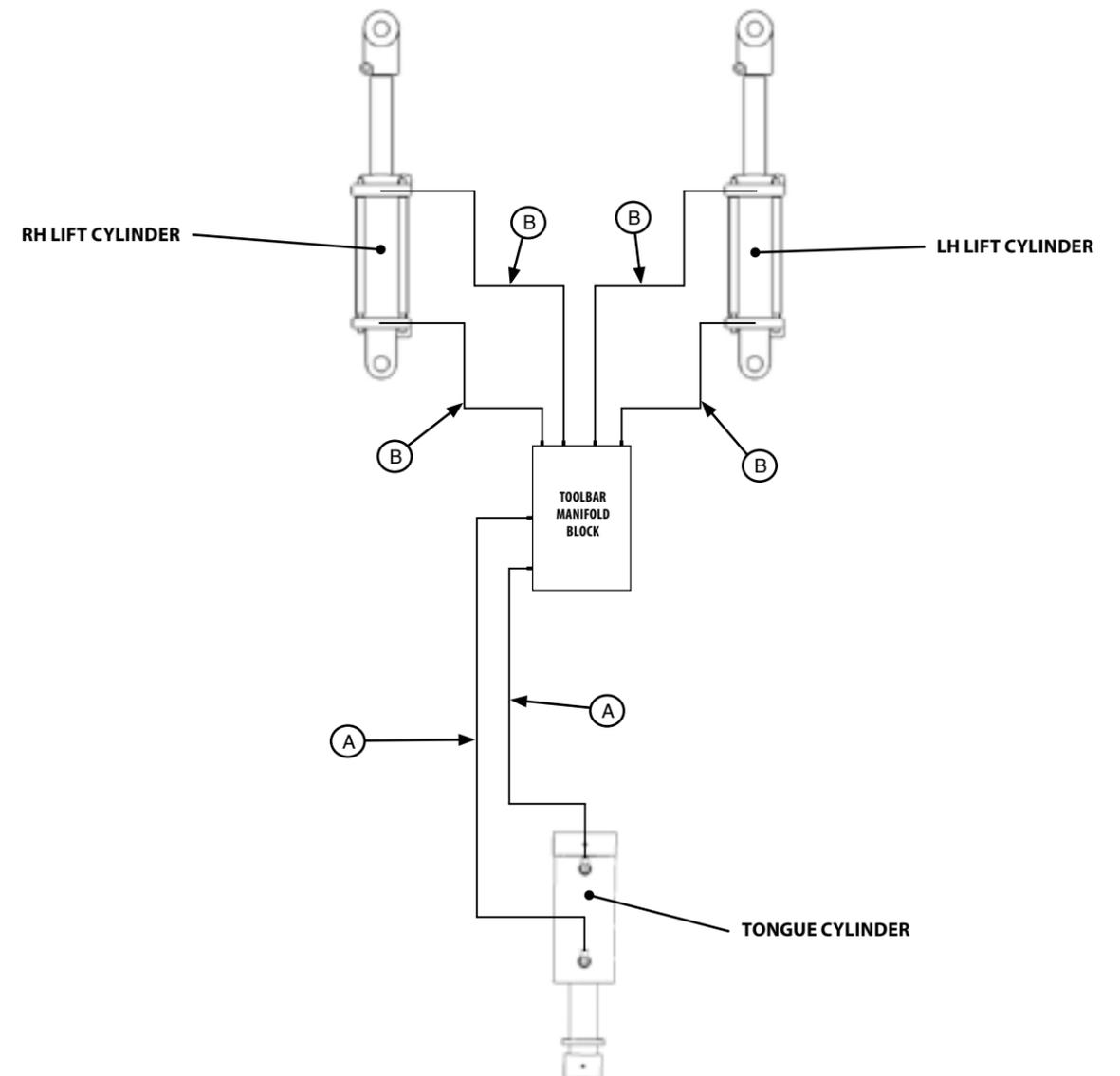

Parts list located on the following page.

MACHINE LIFT HYDRAULIC HOSES

Key	Part #	Machine Configuration	Qty	Notes
A	196-561	ALL	2	1/2" x 27"; Tongue Cylinder Hoses
		End fittings		9/16FJX x 9/16FJX
B	196-352	ALL	4	1/2" x 132"; Machine Lift Cylinder Hoses
		End fittings		9/16FJX x 9/16FJX

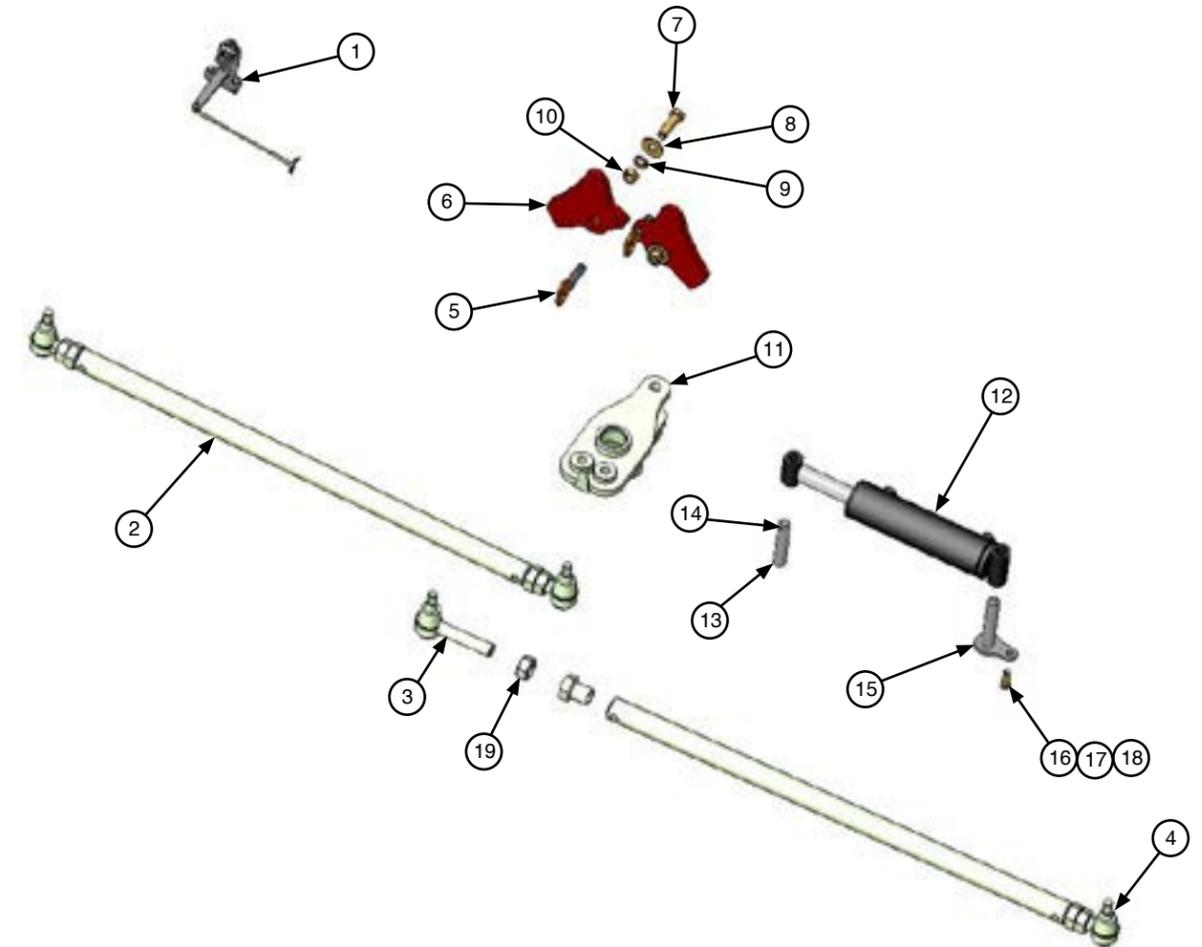

SMART IMPLEMENT GUIDANCE STEERING COMPONENTS

Key	Part #	Description	Qty	Notes	Key	Part #	Description	Qty	Notes
1	BPF10024	Position Sensor	1	----	9	108-022	Lock washer	2	3/4"
2	348-476	Strut	2	30" row spacing	10	102-099	Nut	2	3/4"
	352-110	Strut	2	36" row spacing	11	352-081	Steering Arm	1	----
	352-112	Strut	2	38"/40" row spacing	12	194-601	Hydraulic Cylinder	1	----
	352-111	Strut	2	70 cm row spacing	13	352-113	Pin	1	Rod end of cylinder
3	152-441	Ball joint	2	RH threaded	14	100-113	Bolt	1	3/8" x 2"
4	152-624	Ball joint	2	LH threaded	15	348-212	Pin	1	Base end of cylinder
5	104-216	Stay Pin	2	----	16	100-116	Bolt	1	1/2" x 1 1/2"
6	348-634	Safety Lock Plate	2	----	17	108-020	Lock washer	1	1/2"
7	100-160	Bolt	2	3/4" x 3"	18	108-001	Flat washer	1	1/2"
8	108-011	Flat Washer	2	3/4"	19	102-086	Nut - RH threaded	2	102-231 - LH threaded

PARTS IDENTIFICATION

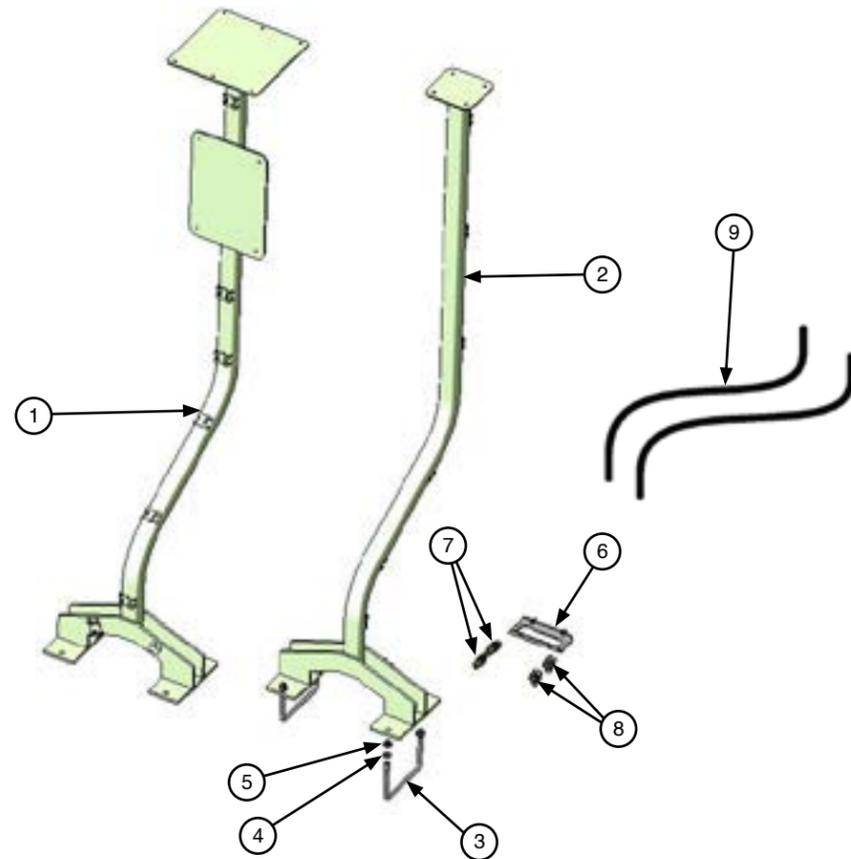

SMART IMPLEMENT GUIDANCE TOOLBAR COMPONENTS

Key	Part #	Description	Qty	Notes
1	348-846	Receiver Tower	1	For Trimble guidance systems. Mounts to toolbar truss.
2	348-848	Receiver Tower	1	For John Deere guidance systems. Mounts to toolbar truss.
3	315-147	U-bolt	2	1/2" - 4" x 7" bar
4	108-020	Lock washer	4	1/2"
5	102-007	Nut	4	1/2"
6	341-829	Hose holder plate	1	Addition to already standard courtesy pallate.
7	198-326	Bulkhead union fittings	2	3/4" MJ x 3/4" MJ
8	198-197	Elbow fitting	2	3/4" MB - 7/16" MJ
9	196-899	Hydraulic hose	2	108" / Routes from bulkhead on tongue to tractor
	196-898	Hydraulic hose	2	288" / Routes from bulkhead on tongue to steering hydraulic cylinder

PARTS IDENTIFICATION

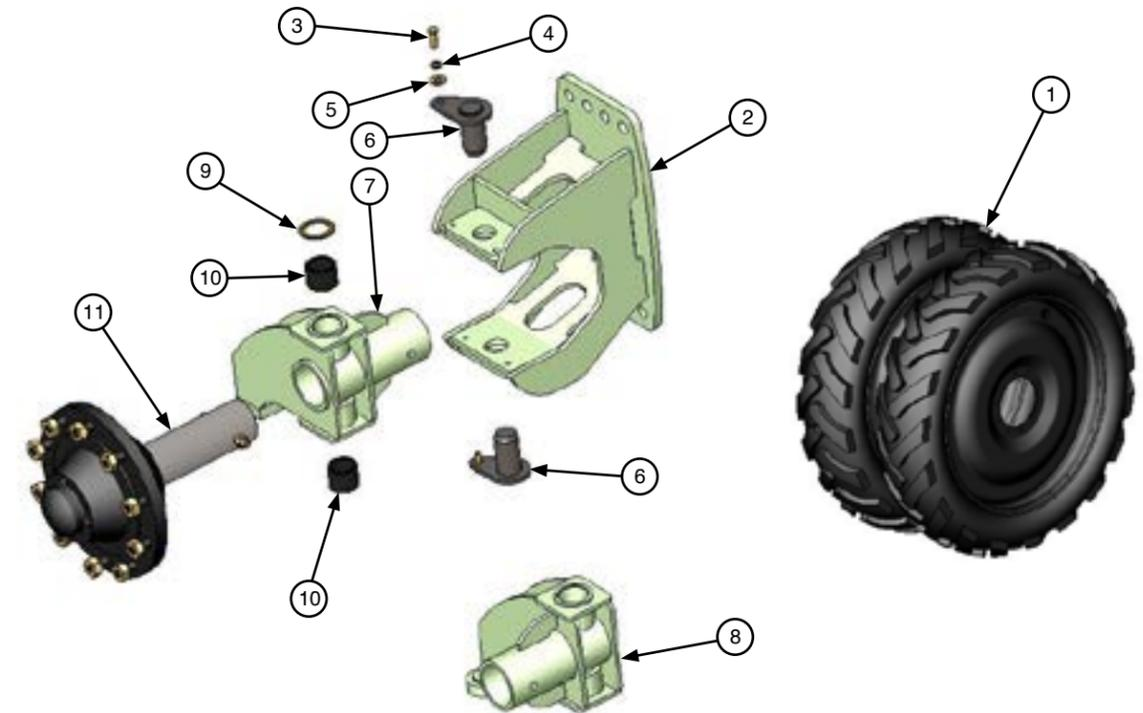

STEERABLE WHEEL AND AXLE ASSEMBLY (SMALL WHEEL)

Key	Part #	Description	Qty	Notes
1	190-100	Tire and Rim (LH and RH)	2	14.9R46 Tires package
2	348-505	Knuckle mount	2	----
3	100-116	Bolt	2	1/2" x 1 1/2"
4	108-020	Lock washer	2	1/2"
5	108-009	Flat washer	2	1/2"
6	348-210	Pin	2	----
7	348-427	Steering knuckle	1	LH side of machine only
8	348-435	Steering knuckle	1	RH side of machine only
9	120-291	Bearing, washer	1	----
10	134-133	Bushing	2	Composite greaseless
11	371-842	Spindle assembly	2	For spindle assembly breakdown, refer to 'Small Wheel and Axle Package' parts page.

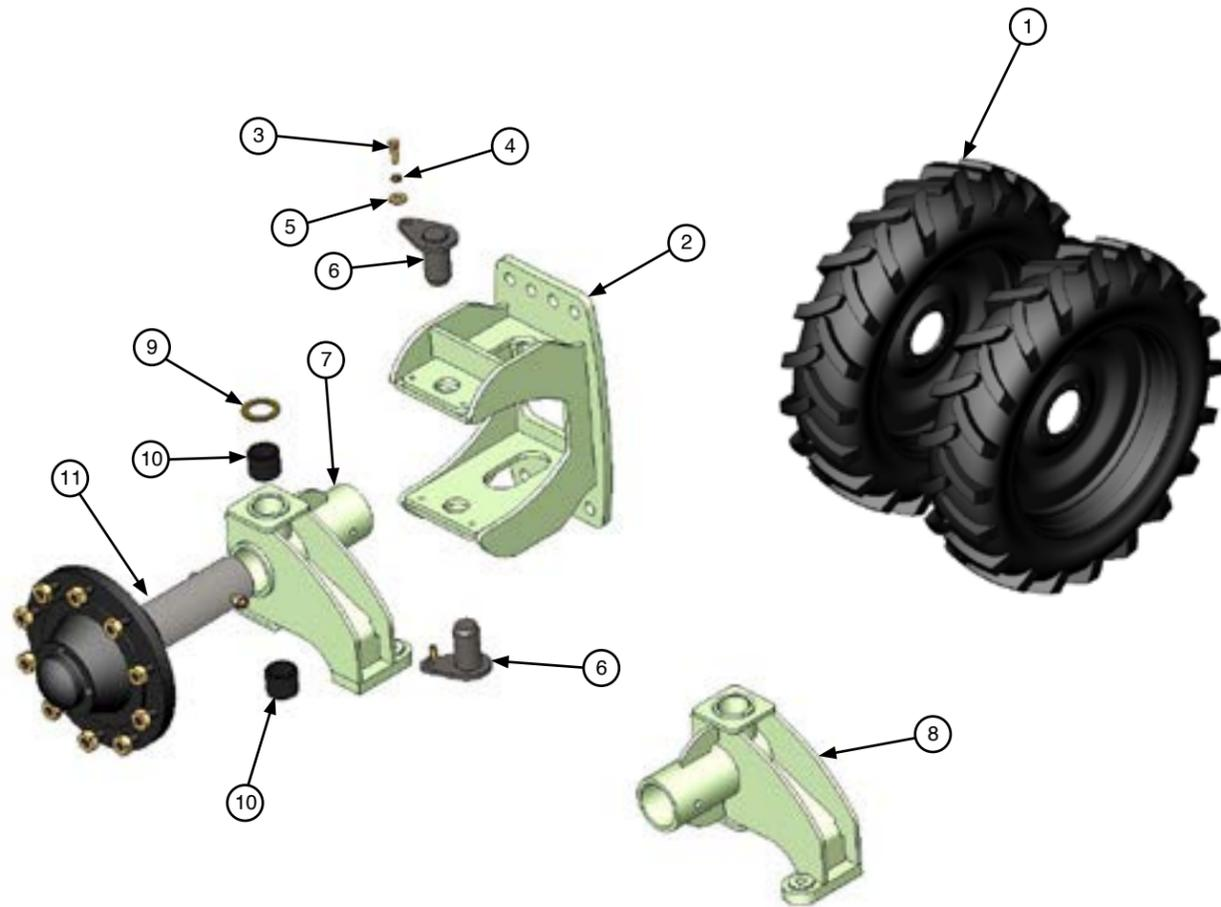

STEERABLE WHEEL AND AXLE ASSEMBLY (LARGE WHEEL)

Key	Part #	Description	Qty	Notes
1	190-148	Tire and Rim (LH and RH)	2	480/80R50 Tires package
2	348-482	Knuckle mount	2	----
3	100-116	Bolt	2	1/2" x 1 1/2"
4	108-020	Lock washer	2	1/2"
5	108-009	Flat washer	2	1/2"
6	348-210	Pin	2	----
7	348-427	Steering knuckle	1	LH side of machine only
8	348-435	Steering knuckle	1	RH side of machine only
9	120-291	Bearing, washer	1	----
10	134-133	Bushing	2	Composite greaseless
11	371-842	Spindle assembly	2	For spindle assembly breakdown, refer to 'Large Wheel and Axle Package' parts page.

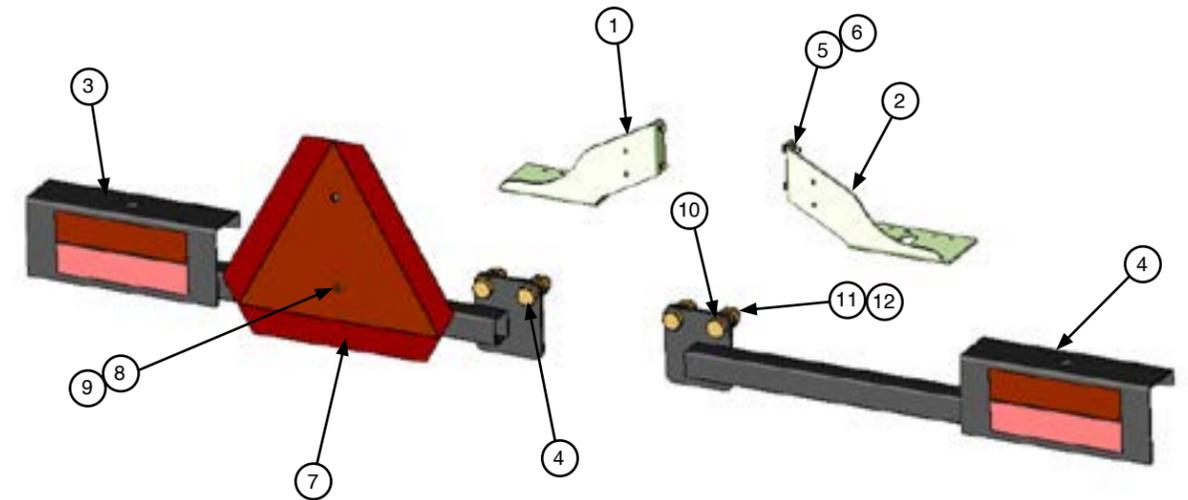

LIGHT BRACKET ASSEMBLY

Key	Part #	Description	Qty	Notes	Key	Part #	Description	Qty	Notes
1	341-772	Light Bracket	1	Front LH	7	153-109	SMV sign	1	----
2	341-774	Light Bracket	1	Front RH	8	102-077	Screw	2	1/4" x 3/4"
3	348-524	Light Bracket	1	Rear LH	9	102-085	Nut	2	1/4"
4	348-528	Light Bracket	1	Rear RH	10	100-157	Bolt	4	3/4"-10 x 2 1/4" GR.5
5	100-001	Bolt	4	Carriage; 1/4"-20 X 1"	11	108-022	Lock Washer	4	3/4"
6	102-227	Nut	4	1/4"-20	12	102-009	Nut	4	3/4"
	303-915	Light Bracket pkg.		Includes items 1-12					

PARTS IDENTIFICATION

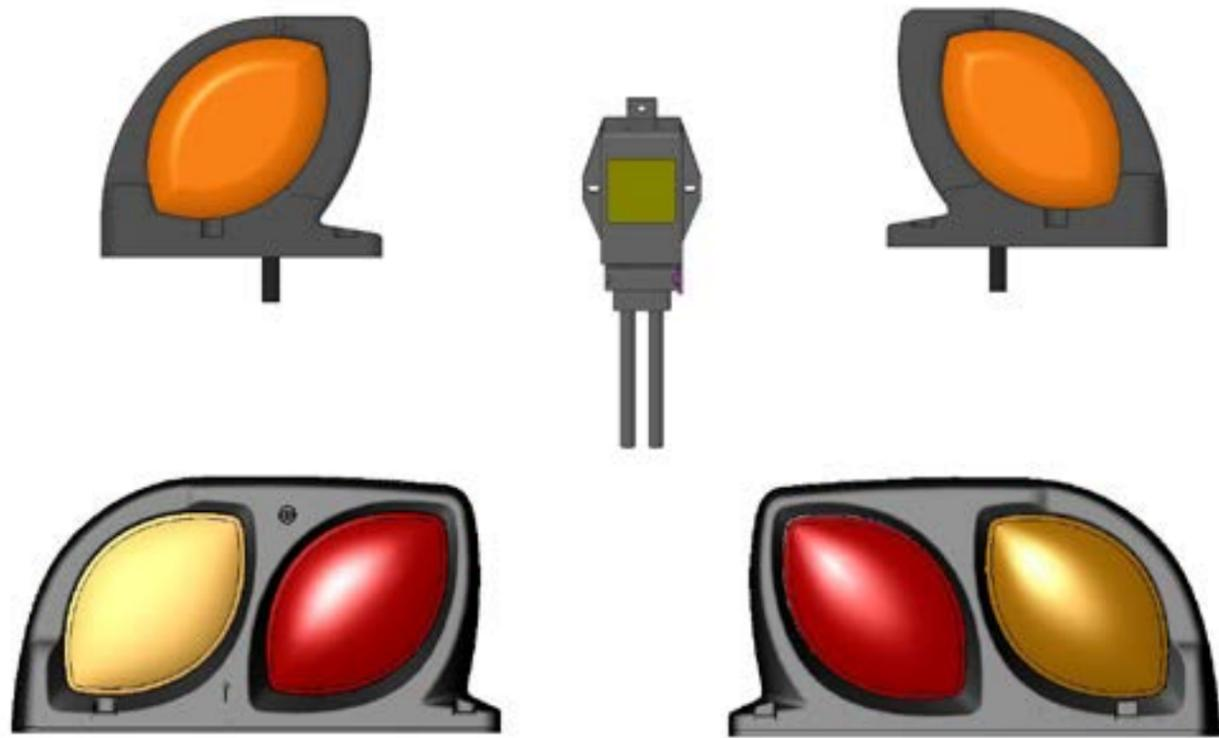

LIGHT KIT ASSEMBLY

Key	Part #	Description	Qty	Notes
	152-850	XD Light Kit	--	Includes all parts in above. Cobo brand
				Call the Orthman parts department for individual replacement lights.

PARTS IDENTIFICATION

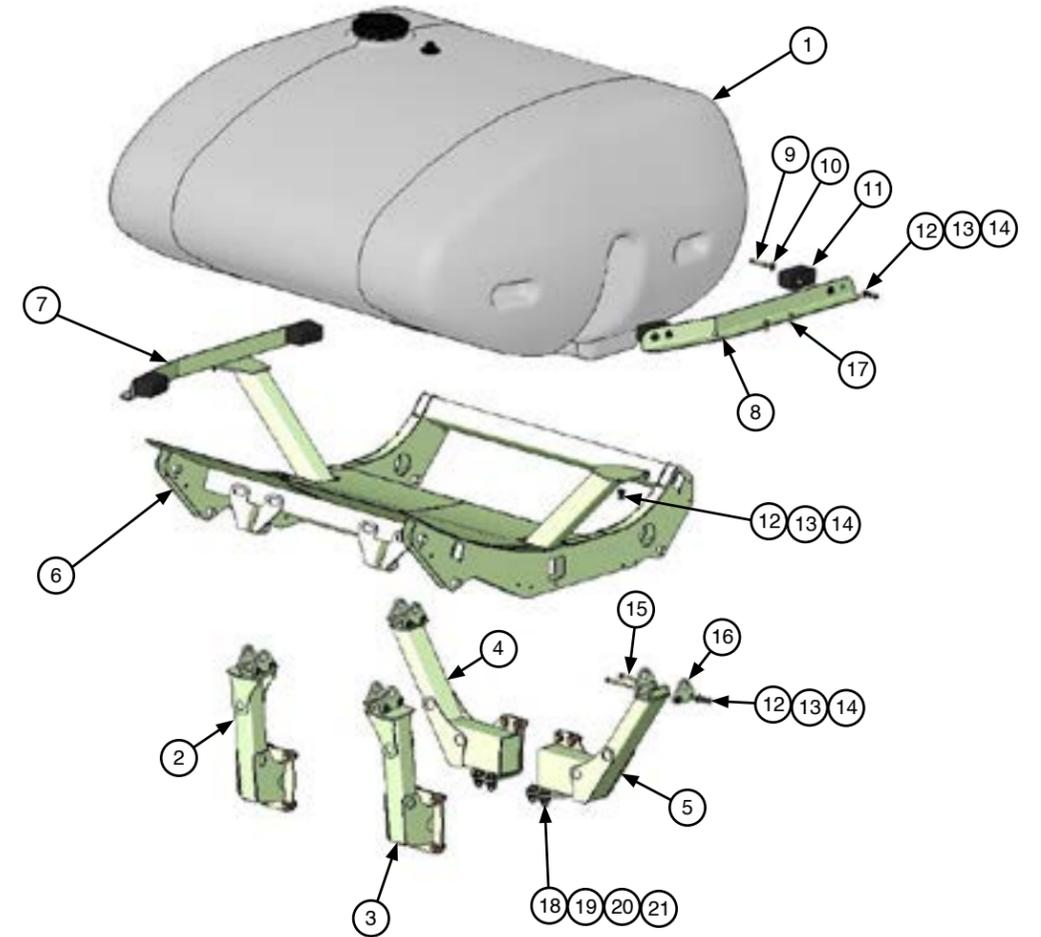

LIQUID FERTILIZER PACKAGE ASSEMBLY

Key	Part #	Description	Qty	Notes	Key	Part #	Description	Qty	Notes
1	152-796	1,000 gal. tank	1	tank w/ fittings	12	102-007	Nut	20	1/2"
2	371-431	RH Front Mount	1	----	13	108-020	Lock washer	20	1/2"
3	371-430	LH Front Mount	1	----	14	108-009	Flat washer	36	1/2"
4	371-433	RH Rear Mount	1	----	15	100-127	Bolt	8	1/2" x 5 1/2"
5	371-432	LH Rear Mount	1	----	16	371-466	Mount Plate	8	----
6	371-469	Tank Saddle	1	1,000 gal. tank	17	100-116	Bolt	4	1/2" x 1 1/2"
7	371-483	RH clamp arm	1	----	18	100-075	Bolt	16	3/4" x 2 1/2"
8	371-484	LH clamp arm	1	----	19	108-011	Flat washer	32	3/4"
9	100-222	Bolt	8	1/2" x 3 1/2"	20	108-022	Lock washer	16	3/4"
10	108-009	Flat washer	36	1/2"	21	102-009	Nut	16	3/4"
11	152-027	Bumper	4	----					

